

Highway User Revenue Fund

Fiscal Year 2001 Year- End Report



ARIZONA DEPARTMENT OF TRANSPORTATION
FINANCIAL MANAGEMENT SERVICES
OFFICE OF FINANCIAL PLANNING
AUGUST 2001

Highway User Revenue Fund Executive Summary

The State of Arizona taxes motor fuels and collects fees relating to the registration and operation of motor vehicles, including gasoline and use fuel taxes, motor carrier fees, motor vehicle registration fees, vehicle license taxes (VLT), and other miscellaneous fees. Revenues are deposited in the Arizona Highway User Revenue Fund (HURF) and are then distributed to the cities, towns and counties and to the State Highway Fund. These fees and taxes are the primary source of revenue to the state for highway construction, improvements and other related expenditures.

For FY 2001, HURF collections totaled \$1,030.9 million, an increase of 1.1 percent over FY 2000, which is an \$11.4 million increase. However, HURF revenues fell short of the forecast of \$1,042.7 million by 1.1 percent. Gas tax and VLT collections posted gains over the FY 2000 revenue levels, while use fuel tax, motor carrier, registration and other revenue categories fell below last year's collections level. Higher fuel prices, economic uncertainty and the slowdown in the national economy accounted for the lower than expected HURF revenue growth.

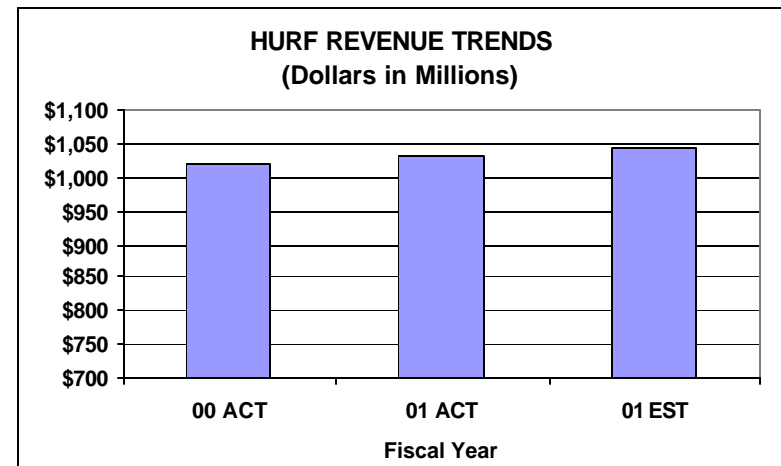

Revenue Trend Analysis

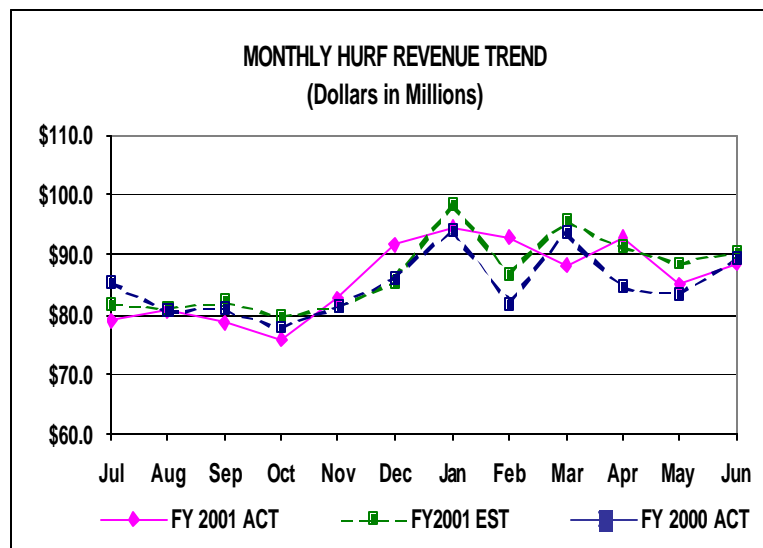
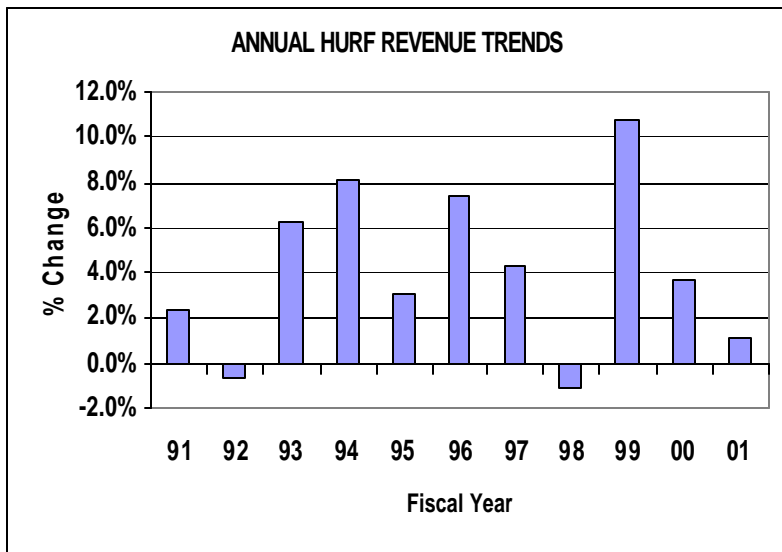

The annual revenues continue to be volatile with slower growth experienced over the past two fiscal years. The year-over-year HURF growth slowed from 3.7 percent in FY 2000 to 1.1 percent in FY 2001. The slower growth in HURF collections was due to higher fuel prices, the slowdown in the national economy and a one cent per gallon reduction in the use fuel tax rate.

The monthly revenue trend is consistent with the cyclical nature of HURF collections, although FY 2001 was less volatile. Staggered registration for commercial motor vehicles in various states has enhanced this trend and should continue to do so.

Performance By Category

Gas Tax:

In FY 2001, gas tax collections totaled \$418.4 million, exceeding FY 2000 collections by 2.3 percent and 0.8 percent above the estimate. Gas tax is the largest component of HURF collections, at approximately 40.6 percent of total receipts for FY 2001. However, the growth rate slowed from 2.9 percent in FY 2000 to 2.3 percent in FY 2001.

Higher gas prices and economic uncertainty led to lower growth in gas tax collections in FY 2001. During FY 2001, regular unleaded gas prices in Arizona rose over \$1.70 per gallon. Furthermore, Arizona's population growth has seen a gradual decline leading to lower gas tax revenue growth.

The Arizona Blue Chip in its June 2001 issue reported that for CY 2000 the actual Arizona wage and salary employment growth rate was 3.9 percent and the personal income was 9.1 percent. For CY 2001, the Arizona Blue Chip estimates are lower with a 3.1 percent growth in wage and salary employment growth and 6.3 percent growth in personal income. The wage and salary employment and personal income growth rates for CY 2002 are estimated at 3.0 and 6.2 percent, respectively.

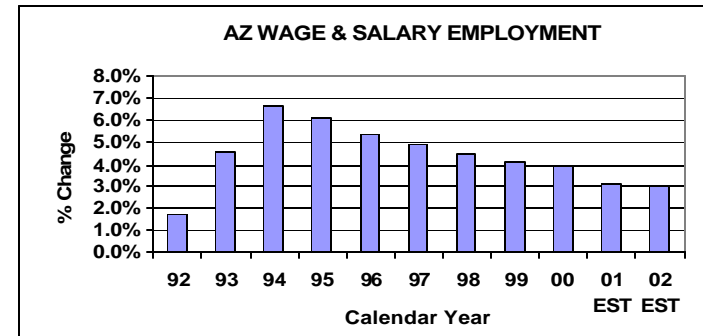
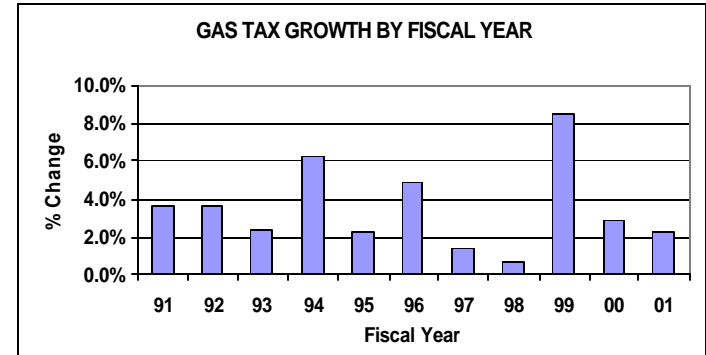

Source: Arizona Blue Chip Forecast, 6/01

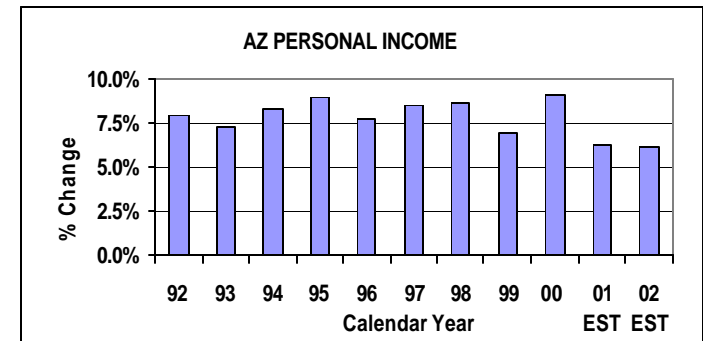

Source: Arizona Blue Chip Forecast, 6/01

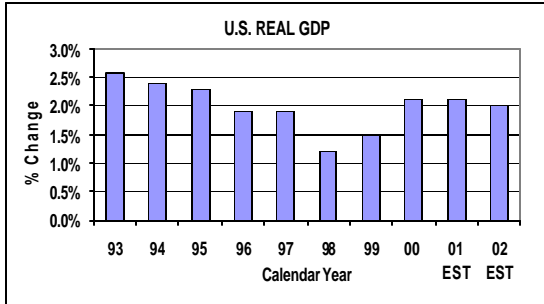
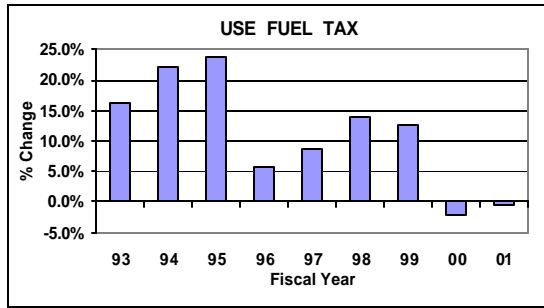

Source: Arizona Blue Chip Forecast, 6/01

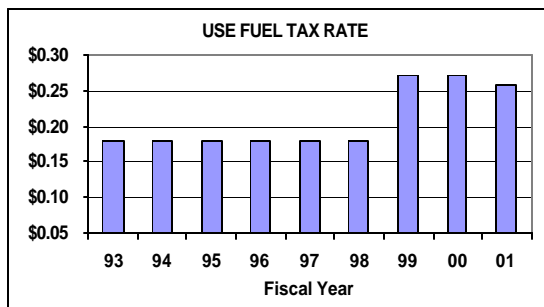
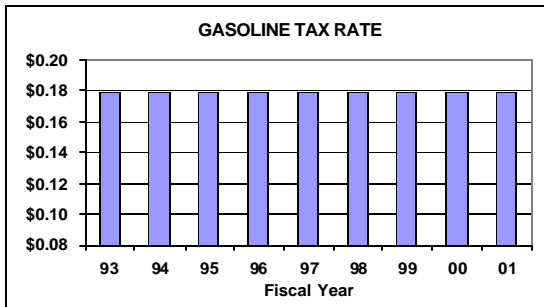

USE FUEL TAX:

In FY 2001, use fuel tax collections were \$155.9 million, a decrease of 0.5 percent from the prior year and 1.1 percent below the estimate. Higher diesel prices, a one cent per gallon reduction in the use fuel tax rate, and a slowdown in the national economy all contributed to the lower revenue growth.

In its June 2001 issue, the Arizona Blue Chip reported the U.S. Real GDP grew at a rate of 2.1 percent for CY 2000. It estimates the U.S. Real GDP will grow at a rate of 2.1 and 2.0 percent during CY 2001 and CY 2002, respectively.

GASOLINE TAX RATE:

The chart on the left shows the gasoline tax rates per gallon in effect at the beginning of each fiscal year. The last tax increase was in FY 1991, bringing the tax rate to its present level of \$.18 per gallon.

USE FUEL TAX RATE:

The use fuel tax rate chart on the left shows the use fuel tax rate per gallon in effect at the beginning of each fiscal year. The large increase in FY 1999 includes a \$0.09 per gallon tax increase imposed on use fuel consumed by “use class” vehicles per Laws 1997, Chapter 8. This increase replaced the \$0.08 per gallon surcharge on use fuel from January 1, 1994 through September 30, 1997, which is not reflected in this chart. On July 1, 2000, the use fuel tax rate was reduced from \$0.27 to \$0.26 per gallon as part of the 1997 legislation.

MOTOR CARRIER FEE:

For FY 2001, motor carrier fee collections were \$32.7 million, a decrease of 10.6 percent from FY 2000 and 11.0 percent below the estimate. The decrease in motor carrier fee collections was due to timing differences when various states shifted to staggered registration and the slowdown in the national economy, which has led to lower manufacturing output and demand for shipment of products. The motor carrier fee collections continue to decrease as a percentage of total HURF collections due to the legislative changes passed in 1994 and 1997, which initially included rate reductions and then the eventual repeal of the Arizona weight distance tax. The motor carrier fee is now a fee based strictly on weight.

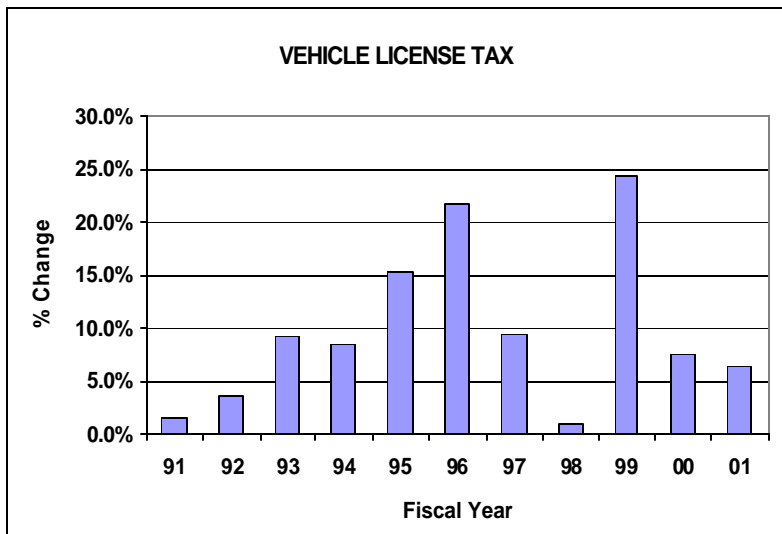
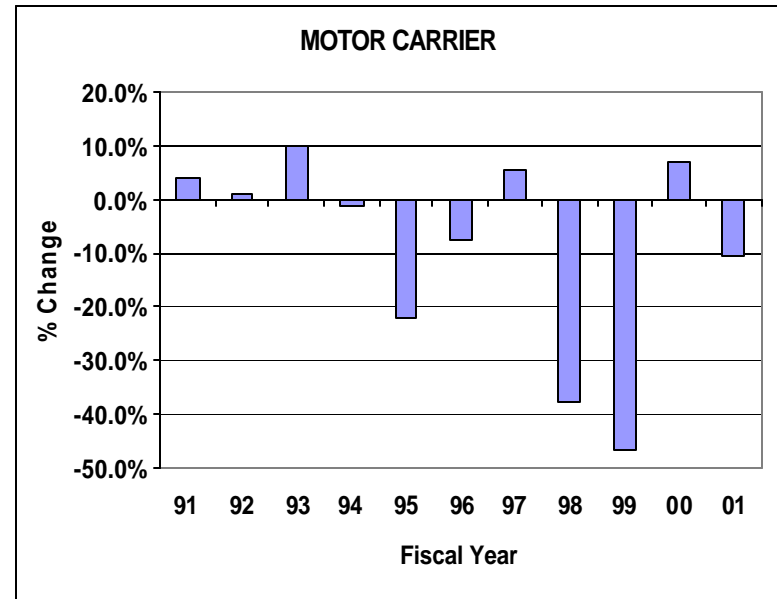

VEHICLE LICENSE TAX:

The VLT revenues totaled \$251.6 million, an increase of 6.4 percent over FY 2000 and 0.2 percent below the estimate. The VLT saw a slower growth rate in FY 2001 due mainly to the economic slowdown, which has impacted Arizona consumer spending. However, lower interest rates have softened the negative impact of the economic slowdown.

REGISTRATION:

For FY 2001, registration collections totaled \$132.3 million, a decrease of 5.8 percent below FY 2000 and 5.7 percent below the estimate. The decrease in registration collections was due mainly to the decrease in apportioned registration fees that motor carriers pay based on their mileage traveled in Arizona compared to the rest of the nation. However, this decrease was partly offset by an increase in the county registration collections from the continued growth in the State’s population.

Arizona’s population was 4.84 million and 4.96 million in CY 1999 and 2000, respectively, which represented an increase of 2.8 and 2.6 percent in growth over the previous year. HURF registration revenue will continue to benefit from the population growth.

OTHER:

In FY 2001, other fees totaled \$40.1 million, a decrease of 0.6 percent from the FY 2000 collections and 2.3 percent below forecast. One of the positive revenue areas in the other fees category was oversized permits with FY 2001 collections totaling \$4.8 million, an increase of 11 percent over FY 2000. In FY 2001, reimbursed credit card fee payments to Motor Vehicle Division (MVD) third party contractors increased by 27 percent over last year, thus reducing collections overall. Other revenues consist of title fees, operator licenses, oversized permits, inquiry fees, use fuel permits, investment interest, and other miscellaneous fees.

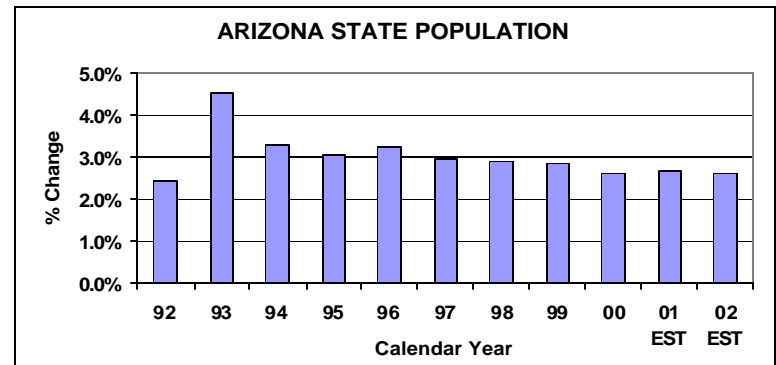
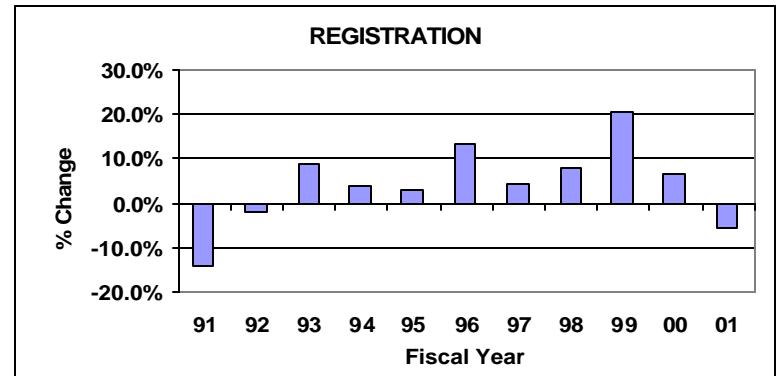

Source: Arizona Blue Chip Forecast, 6/01

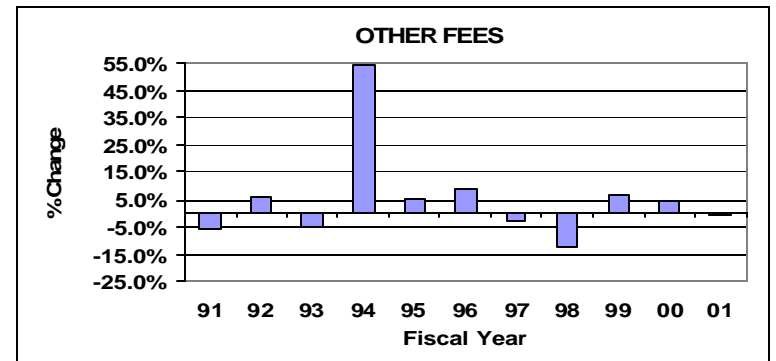

Revenue Composition Comparison

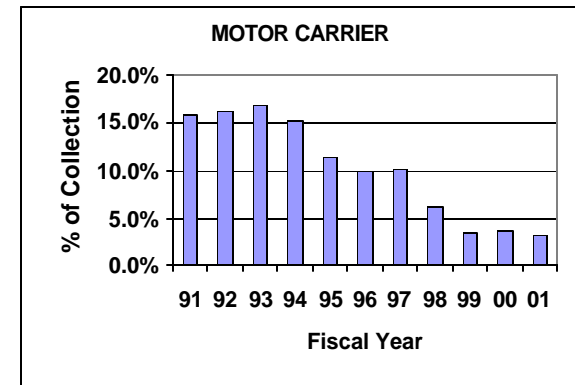
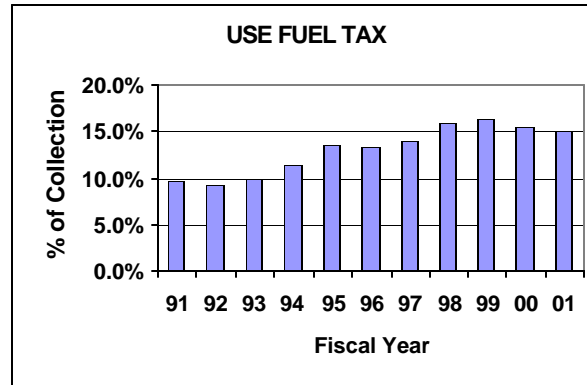
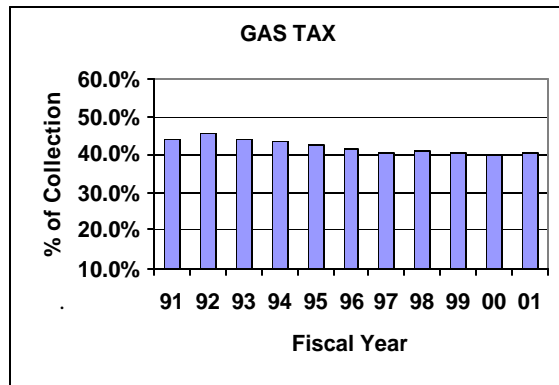

All revenue categories, except VLT and other fees, were negatively impacted by higher fuel prices, lower commercial activity, and the slowdown in the national economy. Motor carrier and registration have been impacted by the 1997 legislation and the slower national economy. The steady increase in VLT has been a result of lower interest rates and higher personal income. Increased credit card reimbursements to MVD third party contractors has limited the growth in the other revenue category.

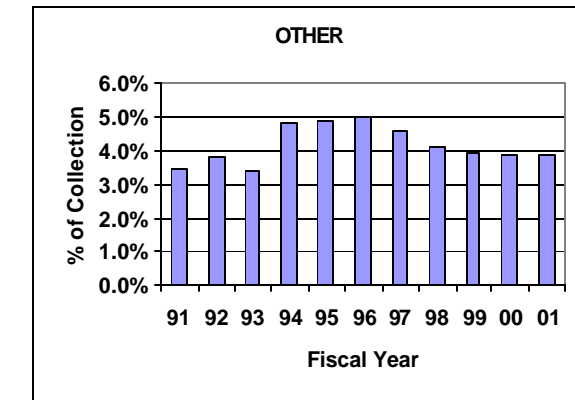
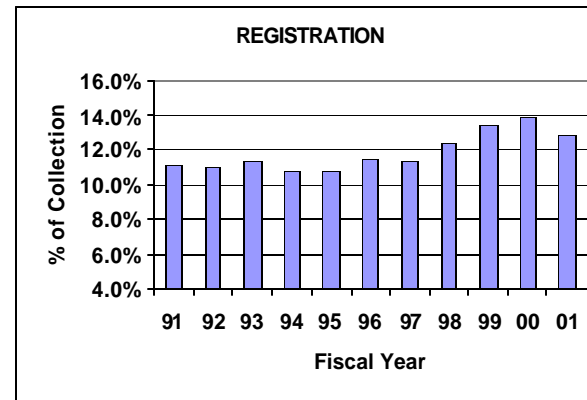
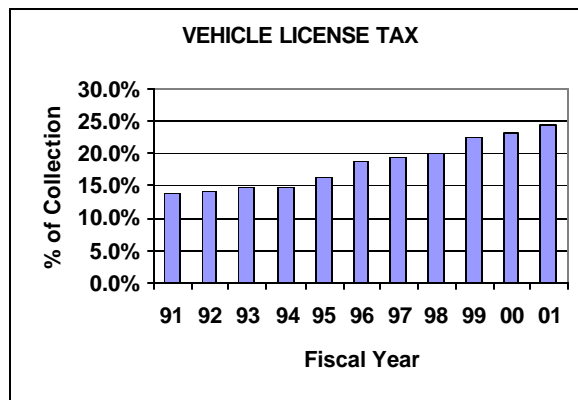

ARIZONA HIGHWAY USER REVENUE FUND

SOURCES AND USES OF FUNDS

FY 2001

TOTAL: \$1,030.9 MILLION

SOURCES

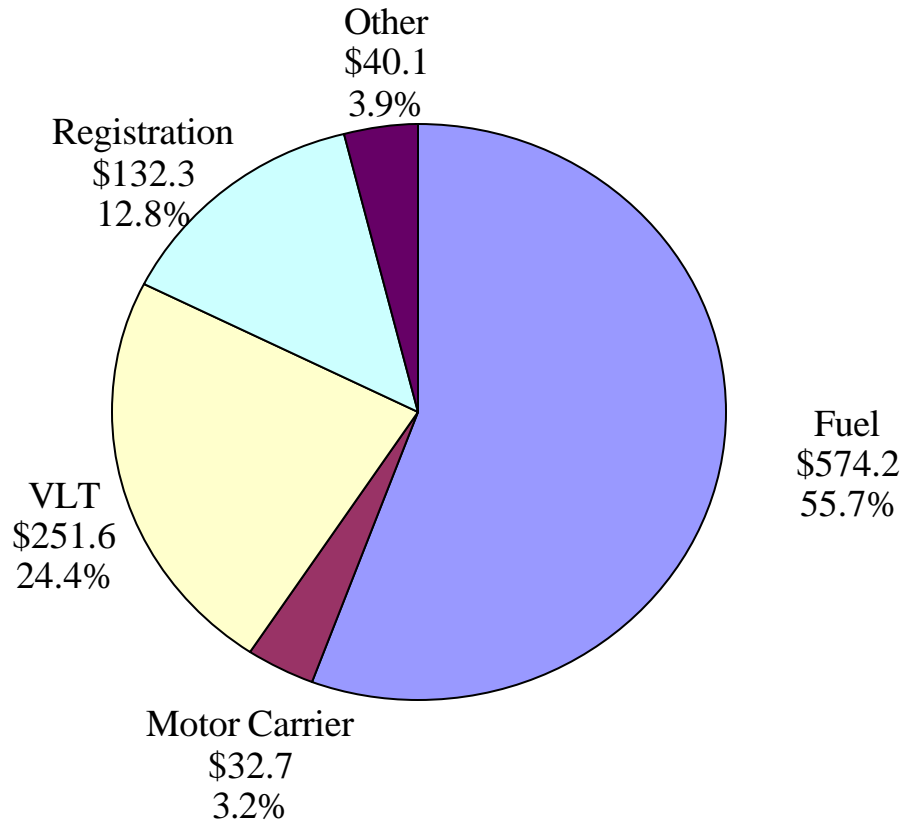

DISTRIBUTION

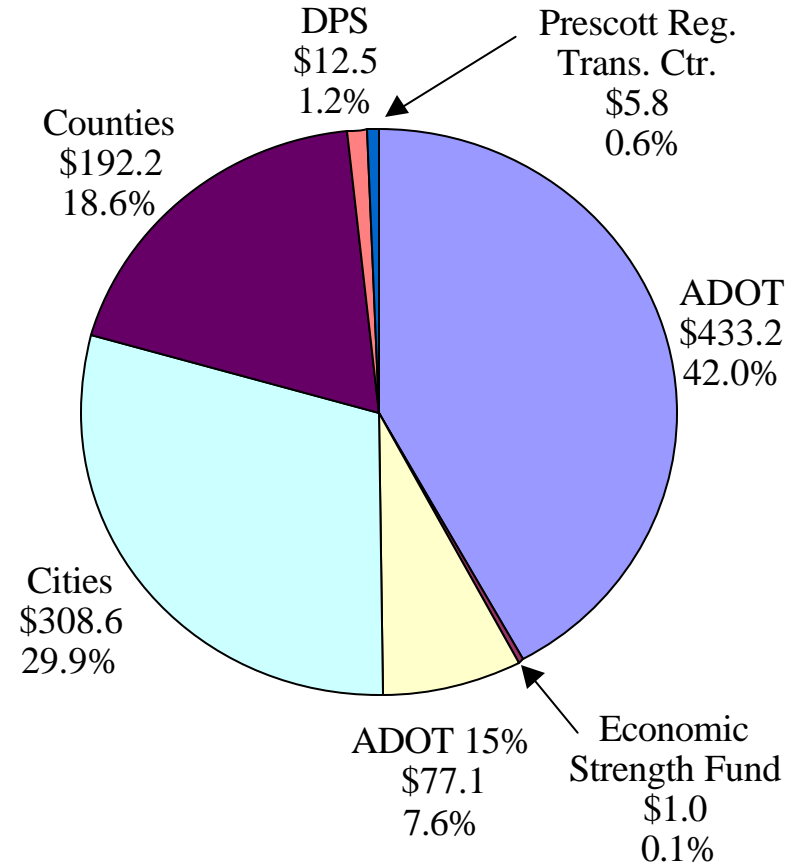

NOTE: ADOT 15% represents ADOT's allocation of HURF for MAG and PAG regional projects.

Arizona Highway User Revenue Fund Revenue Comparison Statement

CATEGORY	FY 2000 ACTUAL	FY 2001 ACTUAL	CHANGE	FY 2001 ESTIMATE	CHANGE
GAS TAX	\$409,137,312	\$418,399,657	2.3%	\$414,900,000	0.8%
USE FUEL TAX	156,598,568	155,859,243	-0.5%	157,600,000	-1.1%
SUBTOTAL	565,735,880	574,258,900	1.5%	572,500,000	0.3%
MOTOR CARRIER	36,562,768	32,677,923	-10.6%	36,700,000	-11.0%
VEHICLE LICENSE TAX	236,547,180	251,612,410	6.4%	252,200,000	-0.2%
COUNTY REGISTRATION	58,910,457	62,370,379	5.9%	60,147,028	3.7%
APPORTIONED	70,266,596	58,757,375	-16.4%	68,671,804	-14.4%
MISC. REGISTRATION	11,167,554	11,141,160	-0.2%	11,381,168	-2.1%
SUBTOTAL	140,344,607	132,268,914	-5.8%	140,200,000	-5.7%
TITLE FEES	6,436,271	6,830,596	6.1%	6,327,327	8.0%
OPERATOR LICENSES	14,957,509	14,076,647	-5.9%	15,284,367	-7.9%
OVERSIZE PERMITS	4,315,132	4,814,005	11.6%	4,418,447	9.0%
INQUIRY FEES	8,511,457	8,332,872	-2.1%	9,891,454	-15.8%
STATION FUEL FEES	1,459,388	1,300,143	-10.9%	1,214,739	7.0%
INVESTMENT INTEREST	2,087,976	2,156,408	3.3%	2,100,003	2.7%
MISCELLANEOUS FEES	2,640,901	2,636,433	-0.2%	1,863,663	41.5%
SUBTOTAL	40,408,634	40,147,104	-0.6%	41,100,000	-2.3%
TOTAL	\$1,019,599,069	\$1,030,965,251	1.1%	\$1,042,700,000	-1.1%

Arizona Highway User Revenue Fund

Revenue Collections By Category

(Dollars In Thousands)

FY 1991- 2001

Fiscal Year	Vehicle						General Fund	Total /1
	Gas Tax	Use Fuel Tax	Motor Carrier	License Tax	Registration	Other	Transfer	
1991	\$296,816	\$65,202	\$108,655	\$92,826	\$75,657	\$24,033	\$16,632	\$679,821
1992	307,879	61,910	109,573	96,146	74,180	25,507	0	675,195
1993	315,227	72,008	120,303	105,027	80,717	24,161	0	717,443
1994	334,643	87,913	118,530	113,990	83,826	37,161	0	776,063
1995	342,299	108,790	92,103	131,562	86,159	39,238	0	800,152
1996	358,961	114,780	85,433	160,145	97,601	42,654	0	859,575
1997	363,953	124,748	90,186	175,253	101,528	41,294	0	896,962
1998	366,377	142,167	63,846	176,950	101,722	36,425	0	887,487
1999	397,463	160,312	34,150	220,126	131,952	38,775	0	982,779
2000	409,137	156,599	36,563	236,547	140,345	40,409	0	1,019,599
2001	418,400	155,859	32,678	251,613	132,269	40,147	0	1,030,965
Total	\$3,911,155	\$1,250,288	\$892,020	\$1,760,185	\$1,105,956	\$389,804	\$16,632	\$9,326,041

Note:

/1 Details may not add to the total due to individual rounding.

Arizona Highway User Revenue Fund

Revenue Distributions

(Dollars In Thousands)

FY 1991-2001

FISCAL YEAR	ARIZONA HIGHWAY FUND	MAG CONTROLLED ACCESS	PAG CONTROLLED ACCESS	CITIES AND TOWNS	COUNTIES	DEPT. OF PUBLIC SAFETY/1	ECONOMIC	OTHER	TOTAL/7
							STRENGTH PROJECT FUND/2	MISCELLANEOUS APPROPRIATIONS	
1991	\$294,567	\$39,225	\$13,075	\$208,708	\$123,746		\$500		\$679,821
1992	288,991	38,111	12,704	201,394	119,068	12,453	1,000	1,473 /3	675,195
1993	302,176	39,846	13,282	210,531	124,468	24,928	1,000	1,212 /3	717,443
1994	328,151	43,270	14,423	228,606	135,157	24,925	1,000	532 /3	776,063
1995	339,752	44,890	14,963	237,920	140,627	20,000	1,000	1,000 /4	800,152
1996	365,016	48,607	16,202	256,988	151,762	20,000	1,000		859,575
1997	376,193	50,573	16,858	267,931	166,908	17,500	1,000		896,962
1998	373,206	50,171	16,724	265,803	165,583	15,000	1,000		887,487
1999	413,371	55,571	18,524	294,410	183,403	12,500	1,000	4,000 /5	982,779
2000	430,668	57,896	19,299	306,729	191,077	12,500	1,000	430 /6	1,019,599
2001	433,248	58,243	19,415	308,567	192,222	12,500	1,000	5,770/6	1,030,965
Total	\$3,945,339	\$526,403	\$175,468	\$2,787,587	\$1,694,021	\$172,306	\$10,500	\$14,417	\$9,326,041

Note:

- 1/ In recent fiscal years, the legislature has authorized the distribution of Arizona Highway User Revenue to the Arizona Department of Public Safety for highway patrol expenditures.
- 2/ The Economic Strength Project Fund was statutorily established on May 17, 1989. Money in the fund is to be used for highway projects that provide economic benefits to the State or local jurisdictions.
- 3/ Appropriation to the Motor Vehicle Division for funding of mandatory insurance enforcement administration.
- 4/ Appropriation to the Motor Vehicle Division for improvements to border area ports of entry.
- 5/ Appropriation to the Department of Commerce for Williams Gateway Authority roadway projects.
- 6/ Appropriation for the Prescott Regional Transportation Center.
- 7/ Details may not add to the total due to individual rounding.

HURF DISTRIBUTION TO ARIZONA CITIES AND COUNTIES FY 2000 -2001

COUNTY	CITY	COUNTY \$ 1\}	CITY \$\$ 2\}	COUNTY	CITY	COUNTY \$ 1\}	CITY \$\$ 2\}	COUNTY	CITY	COUNTY \$ 1\}	CITY \$\$ 2\}																																				
Apache		\$5,399,806.62		La Paz		\$2,722,759.54		Pima		\$38,653,952.14																																					
	Eagar		\$673,666.54		Parker		\$894,963.38		Marana		\$517,355.63																																				
	Springerville		\$288,053.93		Quartzite		\$640,786.52		Oro Valley		\$1,779,482.71																																				
	St. Johns		\$503,720.16						South Tucson		\$484,384.03																																				
Cochise		\$6,406,834.26		Maricopa		\$78,350,324.75		Tucson		\$46,216,869.36																																					
	Benson		\$306,184.96		Apache Junction		\$10,890.52		Sahuarita		\$196,724.55																																				
	Bisbee		\$475,332.11		Avondale		\$1,726,651.88																																								
	Douglas		\$1,083,204.11		Buckeye		\$362,945.90		Pinal		\$8,978,039.57																																				
	Huachuca City		\$141,402.28		Carefree		\$169,923.52		Apache Junction		\$1,852,838.45																																				
	Sierra Vista		\$2,777,939.24		Cave Creek		\$226,987.80		Casa Grande		\$1,939,207.79																																				
	Tombstone		\$103,508.15		Chandler		\$9,865,632.61		Coolidge		\$650,213.66																																				
	Wilcox		\$261,131.00		El Mirage		\$428,084.26		Eloy		\$825,687.57																																				
Coconino		\$10,083,529.43			Fountain Hills		\$1,061,520.91		Florence		\$1,078,901.97																																				
	Flagstaff		\$7,969,702.75		Gila Bend		\$128,162.71		Kearny		\$223,274.21																																				
	Fredonia		\$186,701.71		Gilbert		\$4,588,459.58		Mammoth		\$178,725.75																																				
	Page		\$1,186,900.70		Glendale		\$13,478,846.81		Superior		\$316,967.44																																				
	Williams		\$408,645.31		Goodyear		\$725,328.33		Queen Creek		\$785.47																																				
	Sedona		\$404,758.10		Guadalupe		\$395,237.70		Winkelman		\$14.01																																				
Gila		\$3,248,194.60			Litchfield Park		\$272,776.23		Santa Cruz		\$2,410,458.65																																				
	Globe		\$775,521.58		Mesa		\$30,233,015.02		Nogales		\$2,150,659.83																																				
	Hayden		\$99,675.12		Paradise Valley		\$911,329.89		Patagonia		\$98,126.27																																				
	Miami		\$222,187.64		Peoria		\$5,606,099.92																																								
	Payson		\$1,228,321.86		Phoenix		\$102,598,385.82		Yavapai		\$8,735,352.28																																				
	Winkelman		\$71,834.16		Queen Creek		\$229,613.85		Camp Verde		\$749,567.58																																				
Graham		\$1,910,113.10			Scottsdale		\$12,419,637.99		Chino Valley		\$629,314.22																																				
	Pima		\$148,927.71		Surprise		\$889,419.36		Clarkdale		\$261,705.45																																				
	Safford		\$707,418.26		Tempe		\$11,213,830.04		Cottonwood		\$663,748.06																																				
	Thatcher		\$317,633.10		Tolleson		\$325,168.81		Jerome		\$44,933.26																																				
Greenlee		\$704,580.85			Wickenburg		\$348,477.83		Prescott		\$3,037,784.26																																				
	Clifton		\$293,770.58		Youngtown		\$197,718.81		Prescott Valley		\$1,635,011.15																																				
	Duncan		\$73,873.82		Mohave		\$9,234,936.30		Sedona		\$621,816.68																																				
					Bullhead City		\$3,026,935.65		Peoria		\$4.13																																				
					Colorado City		\$353,132.70		Yuma		\$8,436,354.33																																				
					Kingman		\$1,875,538.05		Somerton		\$591,793.47																																				
					Lake Havasu City		\$4,046,184.54		San Luis		\$853,490.09																																				
				Navajo		\$6,946,861.22		Welton		\$117,313.06																																					
					Pinetop/Lakeside		\$477,302.64		Yuma		\$6,157,241.47																																				
					Holbrook		\$726,719.42																																								
					Show Low		\$1,011,067.94																																								
					Snowflake		\$595,413.73																																								
					Taylor		\$387,094.09																																								
					Winslow		\$1,533,810.16																																								
			<table border="1" style="width: 100%;"> <tr> <td colspan="2">FISCAL YEAR 2000-2001 TOTALS:</td> <td></td> <td></td> <td></td> <td></td> <td></td> <td></td> <td></td> <td></td> <td></td> <td></td> </tr> <tr> <td>CITIES:</td> <td></td> <td>\$308,567,051.38</td> <td></td> <td></td> <td></td> <td></td> <td></td> <td></td> <td></td> <td></td> <td></td> </tr> <tr> <td>COUNTIES:</td> <td></td> <td>\$192,222,097.64</td> <td></td> <td></td> <td></td> <td></td> <td></td> <td></td> <td></td> <td></td> <td></td> </tr> </table>									FISCAL YEAR 2000-2001 TOTALS:												CITIES:		\$308,567,051.38										COUNTIES:		\$192,222,097.64									
FISCAL YEAR 2000-2001 TOTALS:																																															
CITIES:		\$308,567,051.38																																													
COUNTIES:		\$192,222,097.64																																													

Highway User Revenue Fund Distribution Overview

<p>Revenues from:</p> <p>\$.18 Gas Tax \$.26 Use Fuel Tax (7/00) Vehicle Registration Motor Carrier Fee 44.99% of VLT (12/01) Other -</p>	<p>Distribution breakdown:</p> <p>50.5% to State Highway Fund</p> <p>27.5% to Cities & Towns</p> <p>3% to Cities over 300,000</p> <p>19% to Counties</p>	<p>Distribution formulas:</p> <p>7.67% to Maricopa and Pima Counties for Controlled Access with a 75% and 25% split respectively. (Statutory 12.6% & Special 2.6% money) 42.83% to ADOT Discretionary.</p> <p>One half distributed on basis of incorporated population and one half on the basis of county origin of gasoline sales and city or town population within each county.</p> <p>Distributed to Phoenix, Tucson and Mesa based on population.</p> <p>Distributed based on a portion of gasoline distribution and diesel fuel consumption and on a portion of unincorporated population. The split as follows: 85/15 in FY 1997, 80/20 in FY 1998, 76/24 in FY 1999, and 72/28 in FY 2000 and thereafter)</p>
---	---	---

ARIZONA DEPARTMENT OF TRANSPORTATION FY 2000-2001 HURF ACTUAL REVENUE DISTRIBUTION FLOW (Dollars in Millions)

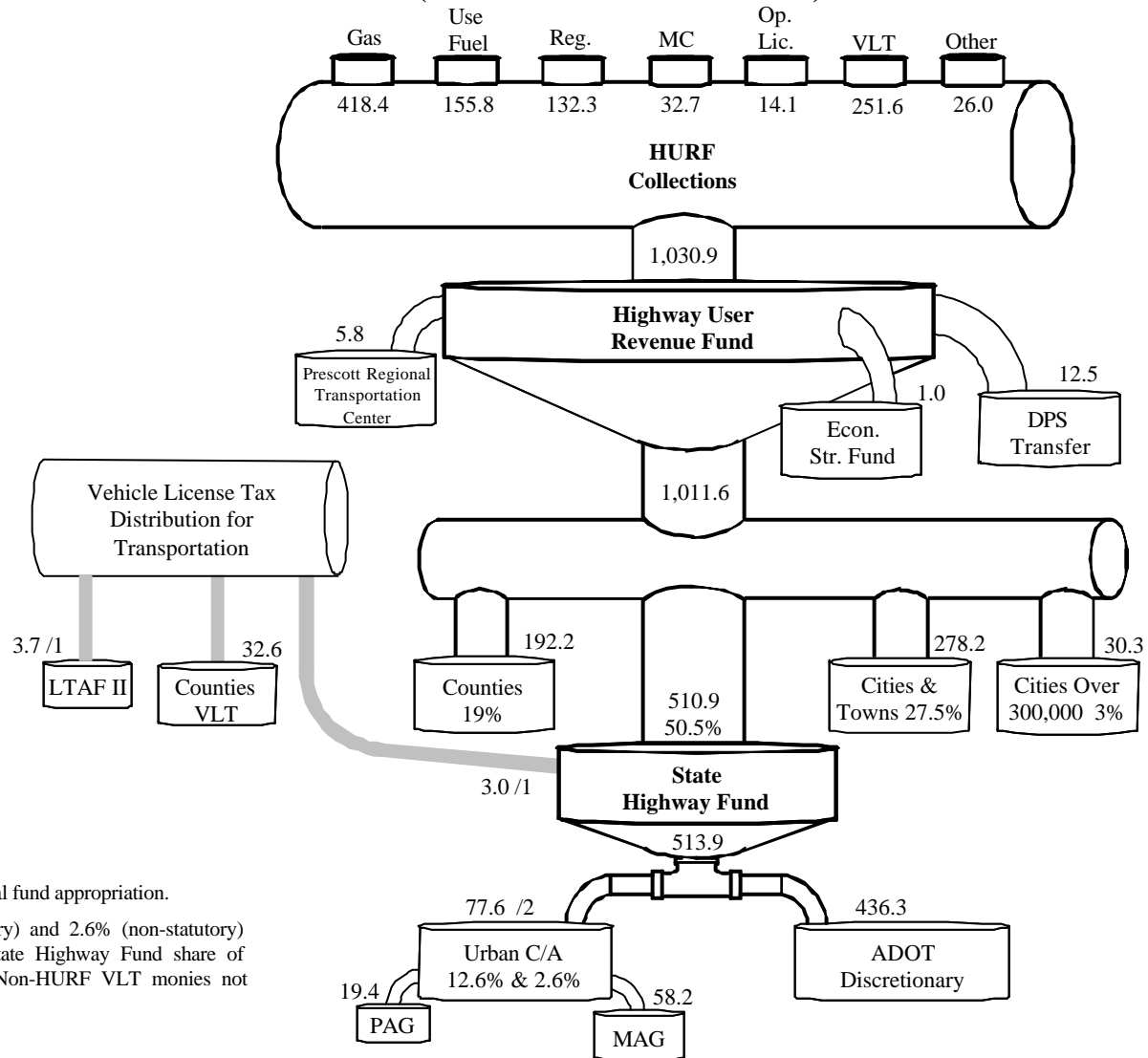

NOTES:

/1. Excludes state general fund appropriation.

/2. The 12.6% (statutory) and 2.6% (non-statutory) allocations from the State Highway Fund share of HURF distributions. Non-HURF VLT monies not included.

REVENUE CATEGORY DEFINITIONS

GASOLINE TAX	A per-gallon tax imposed on gasoline used by vehicles on Arizona highways; presently this tax is \$0.18 per gallon.
USE FUEL TAX	Includes all gases and liquids used to propel motor vehicles on the highways in this state except for motor fuel (gasoline). Use fuel consists primarily of diesel fuel. Diesel fuel tax was \$0.27 per gallon, but dropped to \$0.26 per gallon on July 1, 2000 for “use class” vehicles. “Non-use class” vehicles continue to pay \$0.18 per gallon. Jet fuel is exempt from fuel and use fuel taxes.
MOTOR CARRIER FEE	A fee imposed on certain commercial carriers based on vehicle weight. Category also includes: Motor Carrier License Tax, Motor Carrier Tax Penalties, late fees and interest, and Motor Carrier Permits Tax, and application fees.
VEHICLE LICENSE TAX	An annual license tax imposed on registered vehicles in lieu of property taxes.
REGISTRATION FEES	Is made up of three distinct components which are: County Registration - non-commercial and commercial vehicle registration, and commercial weight fees. Apportioned Registration - commercial registration fees allocated according to miles traveled in Arizona. Miscellaneous Registration - Non-resident Permits, Unassigned Registration, Prorate Stickers, and Registration Penalties.
OTHER FEES	Includes Title Fees, Operator Licenses, Oversize/Overweight Permits, Use Fuel Permits and Fuel Tax Penalties, Investment Interest, Special Plates, and other miscellaneous fees, less credit card fees.