

CASE III - 2:1 (MAX) SLOPING FILL

QUANTITIES

LIMIT STATE NOTES:

Dimensions							Steel List										Service Limit State			Strength Limit State											
H	W	B	C	F	E	X	S1			S2			S3			H	V	Y			F1	T			F2	Q _{tveu-SERV} Lbs./Sq.Ft.	Q _{nveu-SERV} Lbs./Sq.Ft.	B'SERV Ft.	Q _{tveu-STR} Lbs./Sq.Ft.	Q _{nveu-STR} Lbs./Sq.Ft.	B'STR Ft.
							Bar Size	Spacing	Length	Bar Size	Spacing	Length	Bar Size	Spacing	Length			Number	Length	Bar Size		Spacing	Length	Number							
4'	3'-0	1'-0	1'-0	10"	1'-2	1'-0	5	12"	5'-6						4	3'-9	5	12"	2'-0	2	5	12"	2'-6	3	960	600	2.52	1320	830	2.44	
5'	3'-6	1'-0	1'-0	10"	1'-8	1'-0	5	12"	6'-6						6	4'-9	5	12"	2'-6	2	5	12"	3'-0	3	1140	780	2.90	1570	1080	2.80	
6'	4'-2	1'-0	1'-0	10"	2'-4	1'-0	5	12"	7'-6						6	5'-9	5	12"	3'-3	2	5	12"	3'-9	3	1300	940	3.46	1810	1320	3.34	
7'	5'-0	1'-2	1'-2	10"	3'-0	1'-3	5	12"	8'-9						8	6'-9	5	12"	3'-9	3	5	12"	4'-3	4	1470	1090	4.19	2040	1530	4.05	
8'	5'-9	1'-2	1'-4	10"	3'-7	1'-6	6	12"	9'-9						10	7'-9	5	12"	4'-3	3	6	12"	5'-0	4	1600	1220	4.89	2220	1710	4.73	
9'	6'-6	1'-3	1'-6	1'-0	4'-0	1'-9	6	12"	10'-9						10	8'-9	5	12"	4'-9	3	6	9"	5'-6	5	1760	1370	5.55	2450	1930	5.37	
10'	7'-3	1'-3	1'-8	1'-0	4'-7	2'-0	7	12"	12'-0						12	9'-9	5	12"	5'-3	4	7	12"	6'-9	5	1890	1500	6.25	2640	2110	6.06	
11'	8'-3	1'-4	1'-10	1'-2	5'-3	2'-3	7	12"	13'-0						14	10'-9	5	12"	6'-0	4	8	12"	7'-9	6	2030	1630	7.25	2830	2290	7.04	
12'	9'-0	1'-4	2'-0	1'-2	5'-10	2'-6	7	12"	14'-0						14	11'-9	5	12"	6'-6	4	8	12"	8'-6	7	2170	1770	7.95	3020	2480	7.73	
13'	9'-9	1'-6	2'-2	1'-4	6'-3	2'-9	6	12"	6'-3	6	12"	15'-0			16	12'-9	5	12"	7'-0	5	8	9"	9'-3	8	2360	1940	8.58	3290	2730	8.34	
14'	10'-6	1'-8	2'-4	1'-4	6'-10	3'-0	7	12"	8'-6	6	12"	16'-3			18	13'-9	5	12"	7'-6	5	7	6"	9'-0	8	2550	2110	9.22	3560	2970	8.95	
15'	11'-3	1'-10	2'-6	1'-4	7'-5	3'-2	7	14"	6'-6	7	14"	17'-6			18	14'-9	6	14"	8'-3	5	8	7"	10'-9	9	2740	2280	9.86	3830	3210	9.56	
16'	12'-0	2'-0	2'-8	1'-6	7'-10	3'-4	7	12"	6'-9	7	12"	10'-3	5	12"	20	15'-9	5	12"	8'-9	6	8	6"	11'-0	9	2940	2460	10.49	4110	3460	10.18	
17'	12'-6	2'-2	2'-8	1'-6	8'-4	3'-6	8	14"	7'-9	8	14"	11'-0	6	14"	22	16'-9	6	14"	9'-3	6	9	7"	12'-0	9	3220	2720	10.72	4510	3840	10.37	
18'	13'-0	2'-4	2'-10	1'-6	8'-8	3'-8	8	12"	8'-3	8	12"	11'-6	6	12"	22	17'-9	6	12"	9'-6	6	9	6"	12'-6	10	3440	2920	11.02	4830	4130	10.64	
19'	13'-6	2'-6	2'-10	1'-8	9'-0	3'-10	9	14"	8'-9	9	14"	13'-6	6	14"	24	18'-9	6	12"	9'-9	7	9	6"	13'-0	10	3730	3190	11.24	5260	4530	10.83	
20'	14'-0	2'-8	3'-0	1'-10	9'-2	4'-0	9	14"	9'-6	9	14"	14'-3	6	14"	26	19'-9	6	12"	10'-3	7	10	7"	13'-6	11	3960	3400	11.53	5590	4840	11.10	
21'	14'-6	2'-10	3'-2	2'-0	9'-4	4'-2	9	12"	9'-6	9	12"	14'-9	6	12"	26	20'-9	6	12"	10'-6	7	10	6"	14'-0	11	4200	3620	11.82	5930	5150	11.36	
22'	15'-0	3'-0	3'-2	2'-2	9'-8	4'-4	9	12"	10'-3	9	12"	15'-9	6	12"	28	21'-9	7	12"	11'-0	8	10	6"	14'-6	11	4510	3910	12.04	6380	5570	11.54	
23'	15'-8	3'-4	3'-4	2'-4	10'-0	4'-6	9	12"	11'-3	9	12"	16'-9	6	12"	30	22'-9	7	12"	11'-6	8	10	6"	14'-9	12	4790	4150	12.48	6780	5920	11.96	
24'	16'-4	3'-8	3'-6	2'-6	10'-4	4'-8	10	14"	11'-9	10	14"	19'-0	6	14"	30	23'-9	7	12"	12'-0	8	11	7"	15'-9	12	5070	4390	12.93	7190	6270	12.37	
25'	17'-0	4'-0	3'-8	2'-9	10'-7	4'-10	10	12"	13'-0	9	12"	19'-3	6	12"	32	24'-9	7	12"	12'-6	8	11	6"	16'-6	12	5350	4630	13.38	7590	6620	12.79	
26'	17'-6	4'-4	3'-10	3'-0	10'-8	5'-0	10	12"	13'-9	9	12"	20'-3	6	12"	34	25'-9	7	12"	13'-0	9	11	6"	17'-0	13	5670	4910	13.59	8060	7030	12.96	
27'	18'-0	4'-8	4'-0	3'-3	10'-9	5'-2	10	12"	15'-0	9	12"	21'-3	6	12"	34	26'-9	7	12"	13'-0	9	11	6"	17'-6	13	6000	5200	13.81	8540	7460	13.14	
28'	18'-8	5'-0	4'-3	3'-6	10'-11	5'-4	10	12"	13'-9	10	12"	22'-9	6	12"	36	27'-9	7	12"	13'-6	9	11	6"	17'-9	13	6240	5400	14.29	8890	7760	13.59	
29'	19'-4	5'-4	4'-6	3'-9	11'-1	5'-6	10	12"	14'-9	10	12"	24'-0	6	12"	38	28'-9	7	12"	14'-0	10	11	6"	17'-9	13	6490	5610	14.77	9250	8060	14.03	
30'	20'-0	5'-8	4'-9	4'-0	11'-3	5'-8	10	12"	15'-9	10	12"	25'-3	6	12"	38	29'-9	7	12"	14'-6	10	11	6"	18'-0	13	6740	5820	15.25	9600	8360	14.48	

CASE III			
H	Concrete C.Y./Ln.Ft.	Steel Lbs./Ln.Ft.	Steel (Horiz. Lap) Lbs./Splice
4'	.30	27	10
5'	.35	31	12
6'	.41	34	12
7'	.50	40	14
8'	.56	50	16
9'	.68	57	16
10'	.74	71	18
11'	.88	84	20
12'	.96	89	21
13'	1.13	107	24
14'	1.28	123	25
15'	1.44	140	26
16'	1.65	154	28
17'	1.81	181	29
18'	1.97	213	30
19'	2.20	229	32
20'	2.44	248	34
21'	2.69	292	34
22'	2.96	314	36
23'	3.35	320	38
24'	3.77	353	38
25'	4.25	400	39
26'	4.72	417	42
27'	5.22	432	42
28'	5.77	459	43
29'	6.35	473	45
30'	6.95	487	45

Q_{tveu-SERV} = Total equivalent uniform vertical bearing stress to be used only for the evaluation of settlement based on the Service I Limit State as per ADOT SF-1.

Q_{nveu-SERV} = Net equivalent uniform vertical bearing stress to be used only for the evaluation of settlement based on the Service I Limit State as per ADOT SF-1.

B'SERV = Effective footing width to be used only for the evaluation of settlement based on the Service I Limit State as per ADOT SF-1.

Q_{tveu-STR} = Total equivalent uniform vertical bearing stress to be used only for the evaluation of bearing resistance based on the Strength I Limit State as per ADOT SF-1.

Q_{nveu-STR} = Net equivalent uniform vertical bearing stress to be used only for the evaluation of bearing resistance based on the Strength I Limit State as per ADOT SF-1.

B'STR = Effective footing width to be used only for the evaluation of bearing resistance based on the Strength I Limit State as per ADOT SF-1.

For other applicable limit states, perform project specific-analysis using the procedures in ADOT SF-1 (Spread Footing: Bearing Resistance and Settlement).

ADOT SF-1 memorandum is found on the Bridge Group website (Geotech Services LRF Design Memorandums).

QUANTITIES NOTE:

Quantities are shown for information purposes only. The pay item is measured per square foot of wall.

Quantities are for one L.F. of wall except for horizontal steel lap splices and footing steps.

Steel quantities for horizontal lap splices shall be added for wall segments greater than 30 feet, and add a splice for each additional wall segment greater than 30 feet. Horizontal 1'-0 lap splices occur at construction or contraction joints.

Steel and concrete quantities for footing steps shall be added to those shown in the table.

NOTES:

For General Notes, Typical Elevations, Sections and Details see SD 7.01 (1, 2, and 3).

For Structural Excavation Limits and Structure Backfill Limits, see SD 7.01 (4 of 5).

Note to Designer: The information presented in this Standard Drawing has been prepared in accordance with recognized engineering principles and is for general use. It should not be used for specific application without competent professional examination and verification of its suitability and applicability by a licensed professional engineer. Contents within the inner border line shall not be altered.

PRIOR DISTRIBUTION DATE 01/15

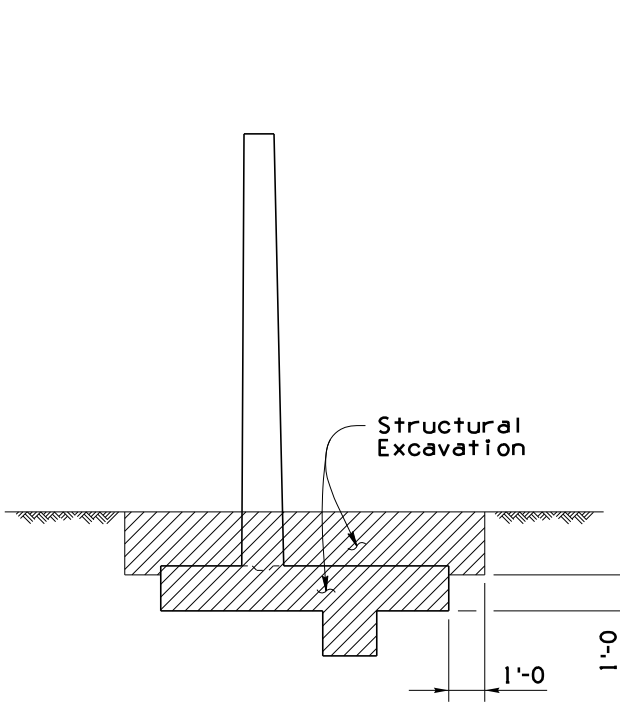

STRUCTURAL EXCAVATION LIMITS

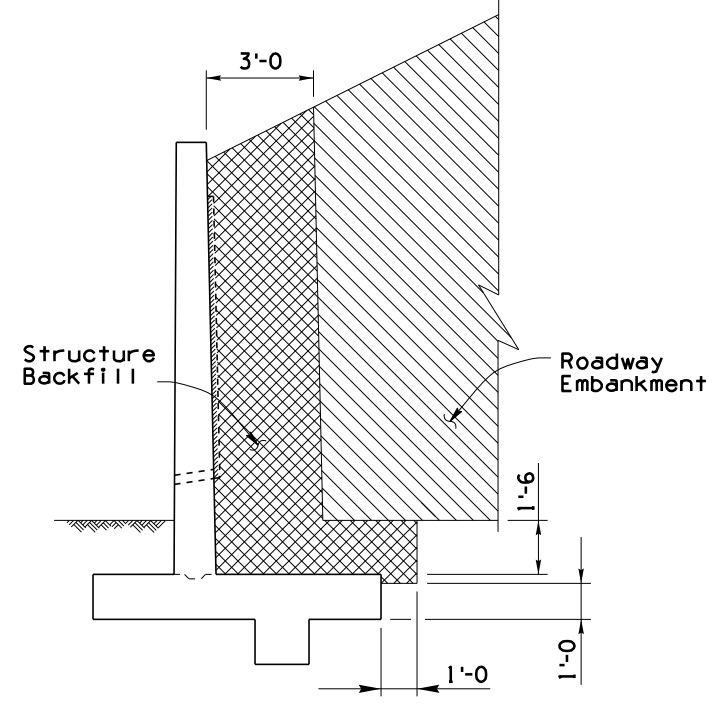

STRUCTURE BACKFILL LIMITS

STANDARDS ENGINEER A. ALZUBI RECOMMENDED FOR APPROVAL GROUP MANAGER	ARIZONA DEPARTMENT OF TRANSPORTATION INFRASTRUCTURE DELIVERY AND OPERATIONS DIVISION BRIDGE GROUP STANDARD DRAWING	
	APPROVED D. EBERHART	RETAINING WALL REINFORCED CONCRETE CANTILEVER
STANDARDS COMMITTEE APPROVED FOR DISTRIBUTION	DATE 12/21	DRAWING NO. SD 7.01 (4 of 5)