

Note to Designer: The information presented in this Standard Detail has been prepared in accordance with recognized engineering principles and is for general use. It should not be used for specific application without competent professional examination and verification of its suitability and applicability by a licensed professional engineer. Contents within the inner border line shall not be altered.

NO.	DESCRIPTION OF REVISIONS	DATE
1	Original Issue	
2		
3		
4		

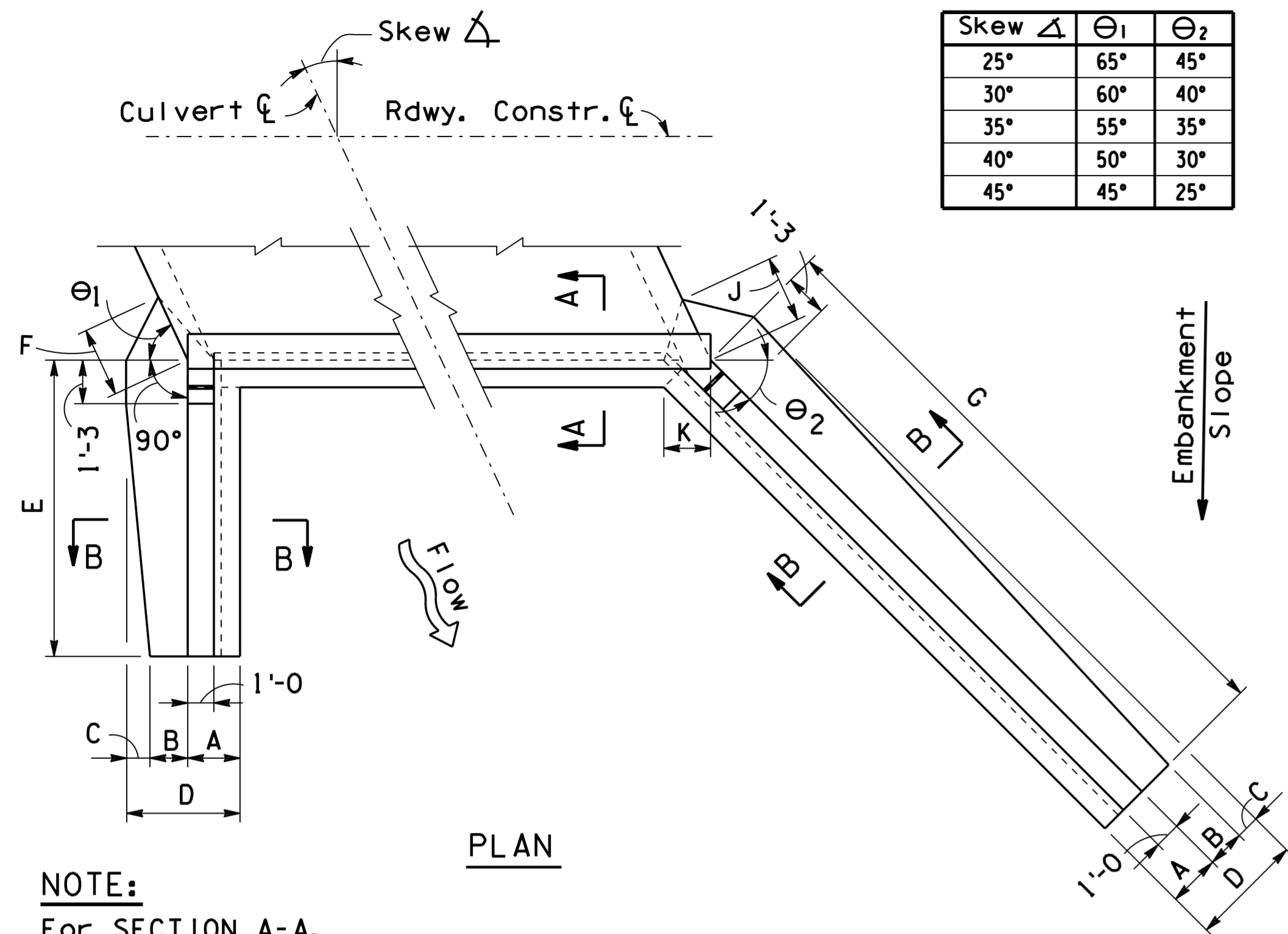

**NOTE:**  
For SECTION A-A, see SD 6.01 (1 of 5).

Skew $\Delta$	25°					30°					35°					40°					45°				
	Height H					Height H					Height H					Height H					Height H				
	A	B	C	D	E	A	B	C	D	E	A	B	C	D	E	A	B	C	D	E	A	B	C	D	E
2:1 Slope	2'-0"	2'-1"	2'-2"	2'-3"	2'-4"	2'-0"	2'-1"	2'-2"	2'-3"	2'-4"	2'-0"	2'-1"	2'-2"	2'-3"	2'-4"	2'-0"	2'-1"	2'-2"	2'-3"	2'-4"	2'-0"	2'-1"	2'-2"	2'-3"	2'-4"

Skew $\Delta$	25°					30°					35°					40°					45°				
	Height H					Height H					Height H					Height H					Height H				
	A	B	C	D	E	A	B	C	D	E	A	B	C	D	E	A	B	C	D	E	A	B	C	D	E
4:1 Slope	2'-0"	2'-1"	2'-2"	2'-3"	2'-4"	2'-0"	2'-1"	2'-2"	2'-3"	2'-4"	2'-0"	2'-1"	2'-2"	2'-3"	2'-4"	2'-0"	2'-1"	2'-2"	2'-3"	2'-4"	2'-0"	2'-1"	2'-2"	2'-3"	2'-4"

Skew $\Delta$	25°					30°					35°					40°					45°				
	Height H					Height H					Height H					Height H					Height H				
	A	B	C	D	E	A	B	C	D	E	A	B	C	D	E	A	B	C	D	E	A	B	C	D	E
6:1 Slope	2'-0"	2'-0"	2'-0"	2'-0"	2'-0"	2'-0"	2'-1"	2'-2"	2'-3"	2'-4"	2'-0"	2'-1"	2'-2"	2'-3"	2'-4"	2'-0"	2'-1"	2'-2"	2'-3"	2'-4"	2'-0"	2'-1"	2'-2"	2'-3"	2'-4"

Skew $\Delta$	'e' Bars		
	Span		
	8'	10'	12'
25° to 30°	*6	*6	*7
35°	*6	*7	*8
40° & 45°	*6	*7	*9

Height H	Short Wing		Long Wing	
	'a' Bars	'b' Bars	'a' Bars	'b' Bars
	8'	*4	*5	*6
9'	*5	*5	*6	*5
10'	*6	*5	*6	*5
11'	*6	*5	*6	*5
12'	*6	*6	*7	*7

Height H	'c' Bars										'd' Bars														
	Long Wing					Short Wing					Long Wing	Short Wing													
	Skew $\Delta$					Skew $\Delta$					All Skew $\Delta$	All Skew $\Delta$													
2:1 Slope	25°					30°					35°					40°					45°				
	Dim 'x'					Dim 'x'					Dim 'x'					Dim 'x'									
4:1 Slope	25°					30°					35°					40°					45°				
	Dim 'x'					Dim 'x'					Dim 'x'					Dim 'x'									

\* 'd' bars alternate with 'a' bars at high end of wall.

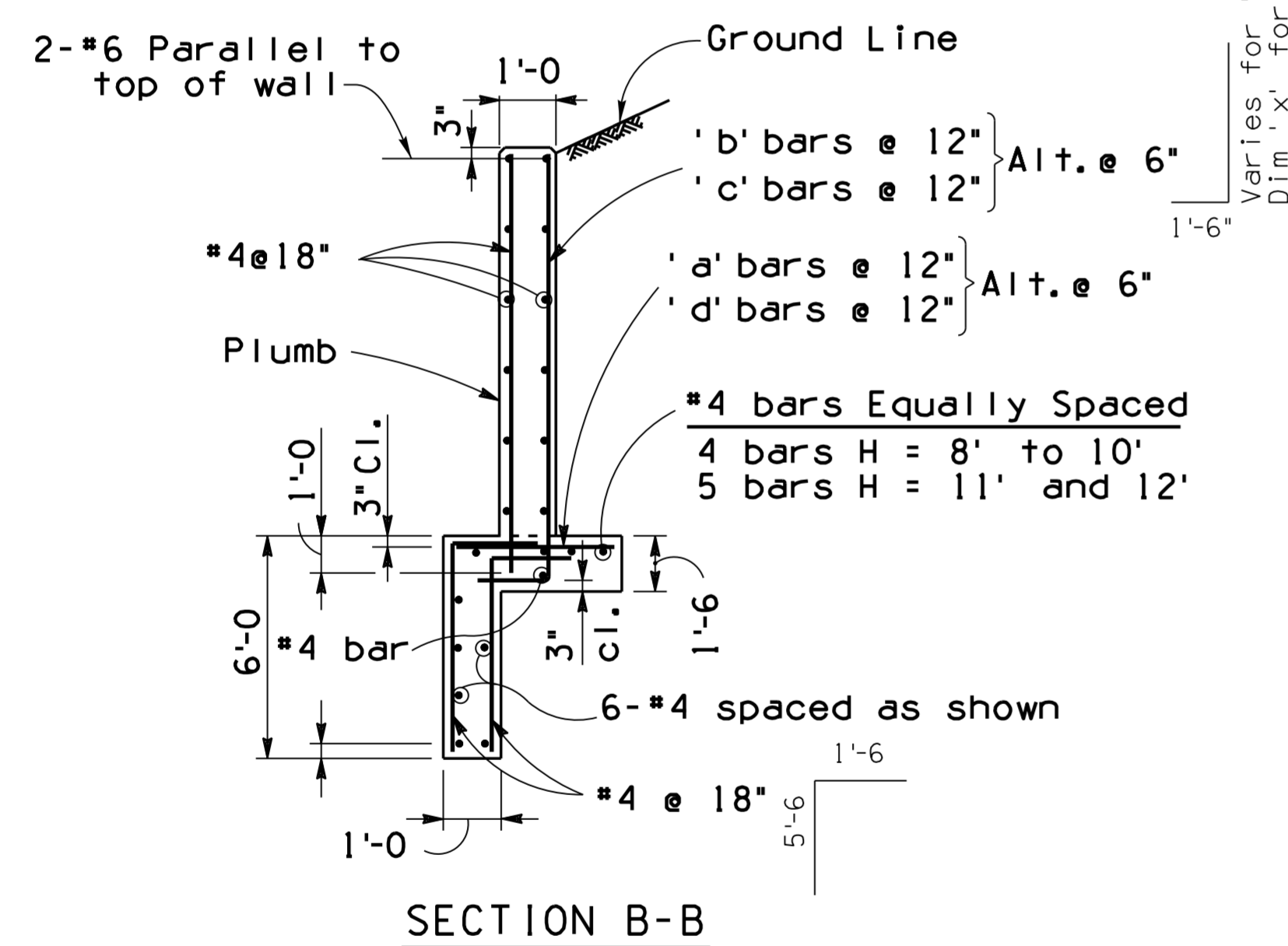

SECTION B-B

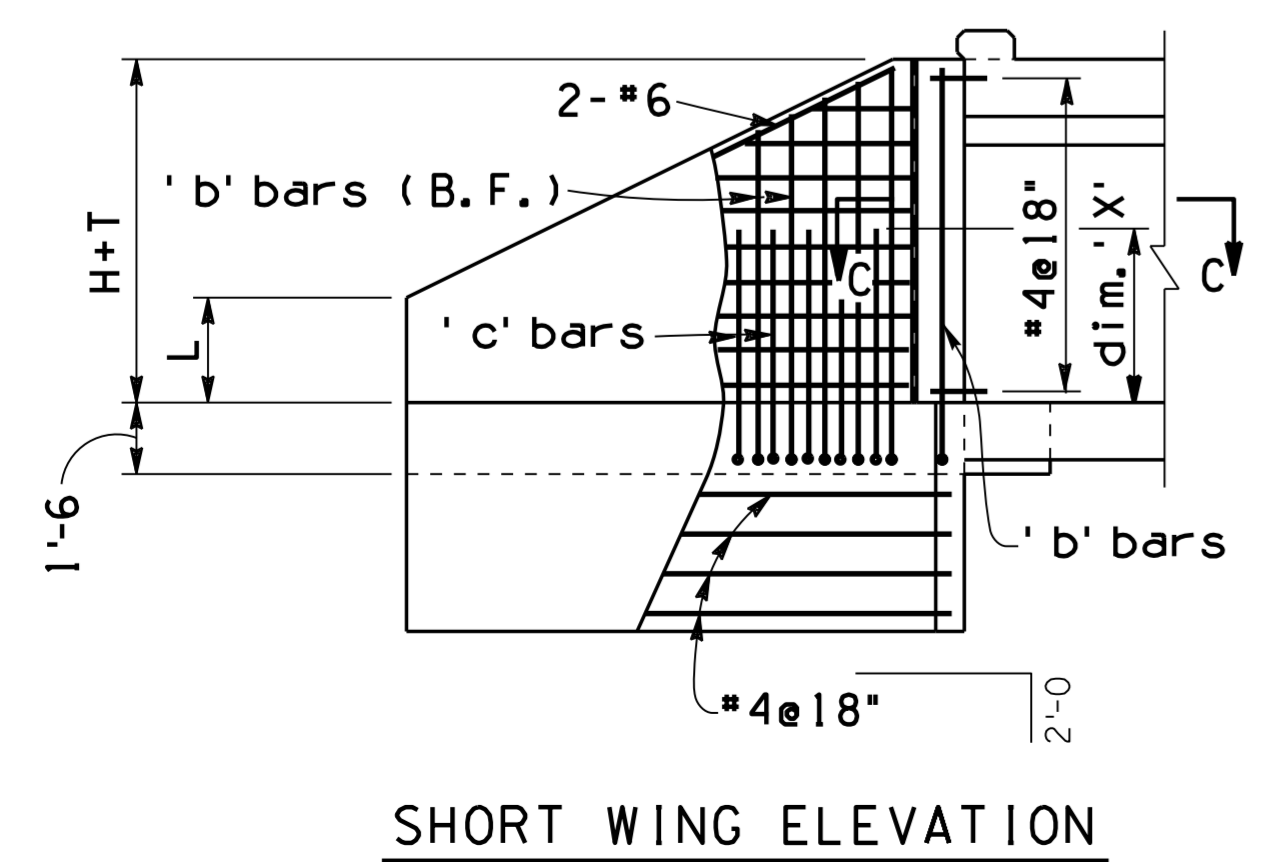

SHORT WING ELEVATION

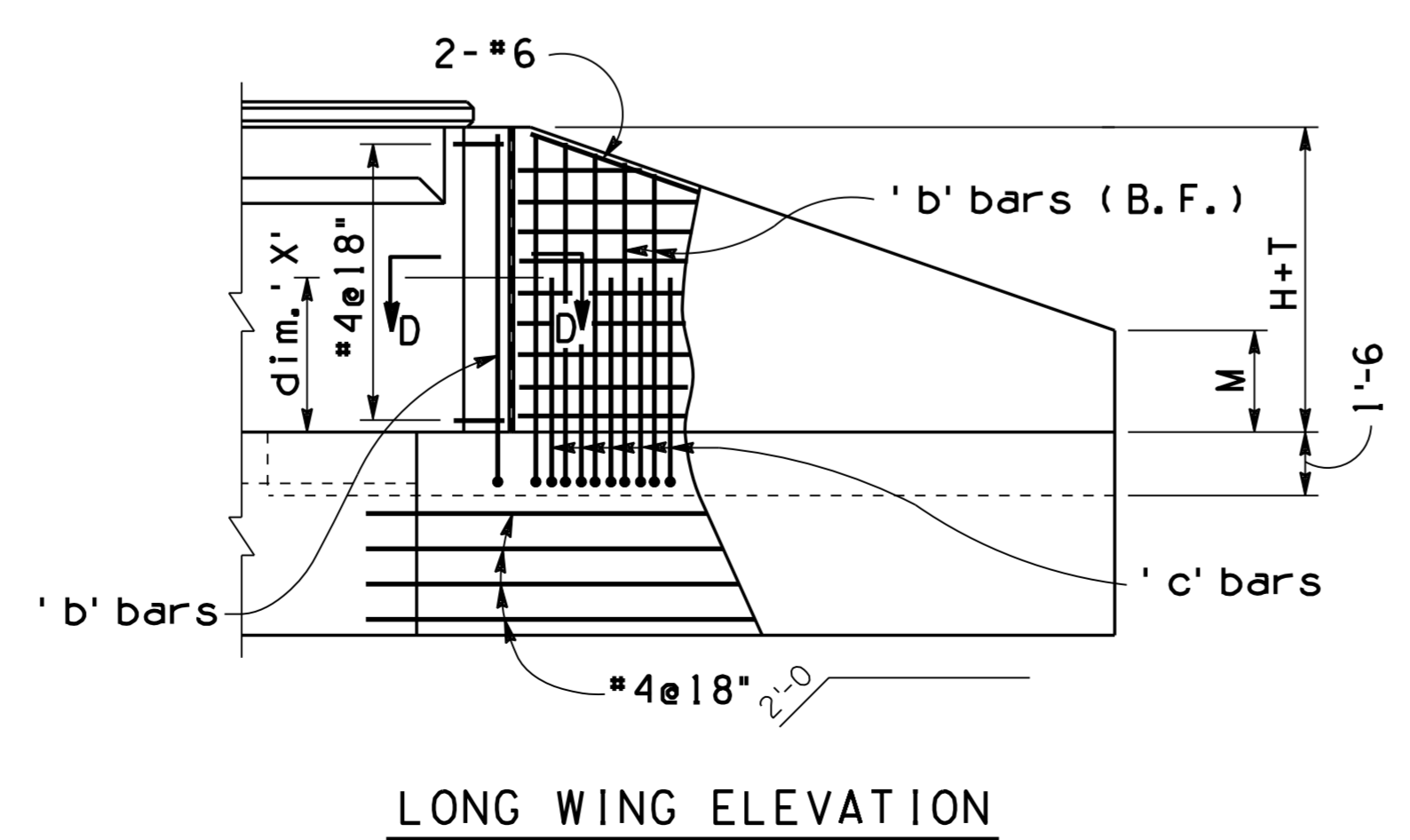

LONG WING ELEVATION

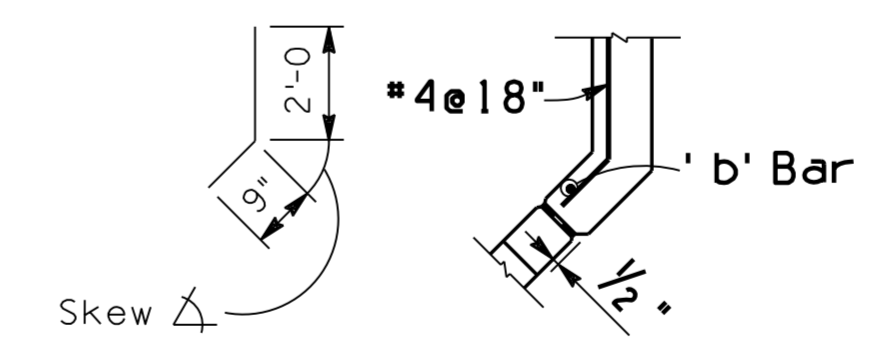

SECTION C-C

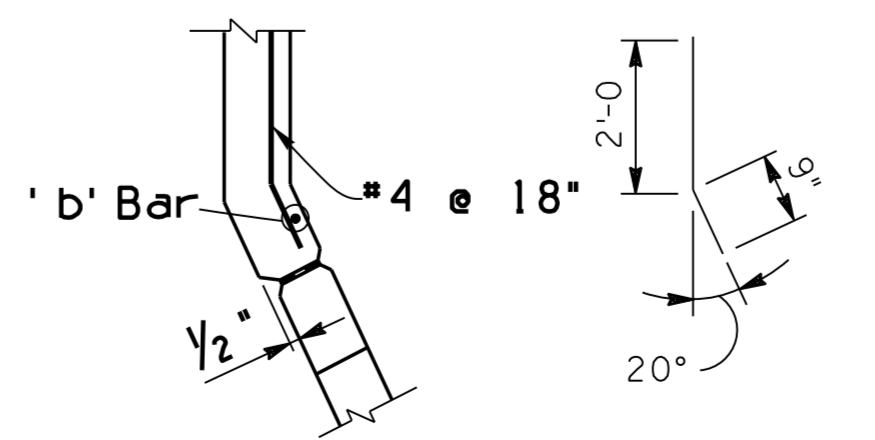

SECTION D-D

**NOTE:**  
For General Notes, Dimensions, and additional Details, see SD 6.01 (1 of 5). For Headwall Quantities see SD 6.09 (1 to 3).

DESIGN APPROVED <i>Shafiq U. Hasan</i>	ARIZONA DEPARTMENT OF TRANSPORTATION INFRASTRUCTURE DELIVERY AND OPERATIONS DIVISION BRIDGE GROUP STRUCTURE DETAIL
APPROVED FOR DISTRIBUTION <i>Teon A. Nehme</i>	REINFORCED CONCRETE BOX CULVERTS OUTLET WINGS - SKEW 25° to 45° CULVERT HEIGHT 8' to 12'
ROUTE PROJECT NO. FA NO.	DRAWING NO. SD 6.08 (6 of 8)
LOCATION	SHEET NO. OF