

## **CALIBRATION OF STANDARD SAND AND SAND CONE APPARATUS**

(A Modification of AASHTO Designation T 191)

### **1. SCOPE**

- 1.1 This method of test is to determine a weight per cubic foot of sand to be used in soil density determinations, and the volume of the sand to fill the funnel and baseplate on the sand cone apparatus.
- 1.2 This test method may involve hazardous materials, operations, and equipment. This test method does not purport to address all of the safety problems associated with its use. It is the responsibility of whomever uses this test method to consult and establish appropriate safety and health practices and determine the applicability of regulatory limitations prior to use.
- 1.3 See Appendix A1 of the Materials Testing Manual for information regarding the procedure to be used for rounding numbers to the required degree of accuracy.

### **2. APPARATUS**

- 2.1 Requirements for the frequency of equipment calibration and verification are found in Appendix A3 of the Materials Testing Manual.
- 2.2 Sand Cone Density Apparatus with Base Plate - A 1 gallon jar and a detachable appliance consisting of a cylindrical valve with an orifice 1/2 inch in diameter and having a small funnel connecting to a standard G mason jar cap on one end and a large funnel on the other end. The valve shall have stops to prevent rotating the valve past the completely open or closed positions. The plate shall have a flanged center hole to receive the large funnel. The apparatus shall conform to the requirements of AASHTO T 191.
- 2.3 Sand to be standardized, clean, dry, free flowing and uncemented
- 2.4 Calibrated 1/13.33 (0.0750) cubic foot mold
- 2.5 Straightedge

2.6 Balance, 20 kg capacity, accurate to 1.0 g, or 35 lb capacity, accurate to 0.01 lb.

### **3. PROCEDURE**

3.1 For determining the density of the sand, the weight of sand to fill the mold is determined as follows:

3.1.1 Fill the jar with the sand to be used and attach the funnel.

3.1.2 Weigh the empty 0.0750 cubic foot mold and baseplate.

3.1.3 Set the mold and baseplate in a flat square pan large enough to catch any excess sand.

3.1.4 Invert the apparatus and set the funnel directly over the mold.

3.1.5 Open the valve and let the sand flow freely into the mold being careful not to jar the apparatus, until the sand ceases to move in the jar. Ensure there are no vibrations in the immediate vicinity.

3.1.6 Close the valve and carefully re-move the apparatus from the mold.

3.1.7 Using the straightedge, strike off the excess sand, being careful not to jar the mold. Work the straightedge in the least number of strokes possible until sand is level with the mold. Tap the side of the mold. Using a brush, clean off excess sand from mold and baseplate, and weigh and record.

3.1.8 Repeat steps 3.1.1 through 3.1.7 twice more.

3.2 For determining the volume of funnel and base plate, the weight of sand to fill the funnel and base plate is determined as follows:

3.2.1 The jar shall now be refilled with the sand, the funnel attached, and the apparatus weighed and recorded.

3.2.2 Place the base plate in the bottom of a level, smooth pan. Ensure that there is not a gap between the baseplate and the bottom of the pan.

- 3.2.3 Invert the apparatus and place on the base plate in the same manner as the apparatus would be placed over a field density hole.
- 3.2.4 Open the valve all the way and allow the sand to flow freely, being careful not to jar the apparatus, until the sand ceases to move. Ensure there are no vibrations in the immediate vicinity.
- 3.2.5 Close the valve and carefully remove the jar and record the weight.
- 3.2.6 Repeat steps 3.2.1 through 3.2.5 twice more.

**4. CALCULATION**

4.1 The calculations are as follows. See Figures 2 and 3 for example forms.

4.1.1 Density of Standard Sand ( $D_s$ ), pcf:

$$D_s = \frac{\text{Average of 3 Weights (grams)}}{(453.6 \text{ g/lb}) \times (\text{volume of mold})}$$

Example:

Trial No.	Wt. of Baseplate and Mold Filled with Sand (grams)	Wt. of Baseplate and Empty Mold (grams)	Wt. of Sand to Fill Mold (grams)
1	9,436	6,649	2,787
2	9,430	6,649	2,781
3	9,429	6,649	2,780
		Total	8,348

The Average of 3 Weights, determined in accordance with Subsections 3.1.1 through 3.1.8, is:

$$\text{Average of 3 Weights} = \frac{8,348}{3} = 2,783$$

Using the equation for  $D_s$  (shown above this example), the Density of Standard Sand in this example is:

$$D_s = \frac{2,783}{(453.6) \times (0.0750)} = 81.8 \text{ pcf}$$

4.1.2 Volume of Funnel and Base Plate, cu.ft.:

$$\text{Volume of Funnel and Base Plate (cu.ft.)} = \frac{\text{Average of 3 Weights (grams)}}{(453.6) \times (D_s)}$$

Example:

Trial No.	Initial Wt. of Apparatus (grams)	Final Wt. of Apparatus (grams)	Wt. of Sand to Fill Funnel and Baseplate (grams)
1	6,348	4,870	1,478
2	6,347	4,871	1,476
3	6,345	4,874	1,471
Total			4,425

The Average of 3 Weights, determined in accordance with Subsections 3.2.1 through 3.2.6, is:

$$\text{Average of 3 Weights} = \frac{4,425}{3} = 1,475$$

Using the equation for the Volume of Funnel and Base Plate (shown above this example), the Volume of Funnel and Base Plate in this example is:

$$\text{Volume of Funnel and Base Plate (cu.ft.)} = \frac{1,475}{(453.6) \times (81.8)} = 0.0398 \text{ cu.ft.}$$

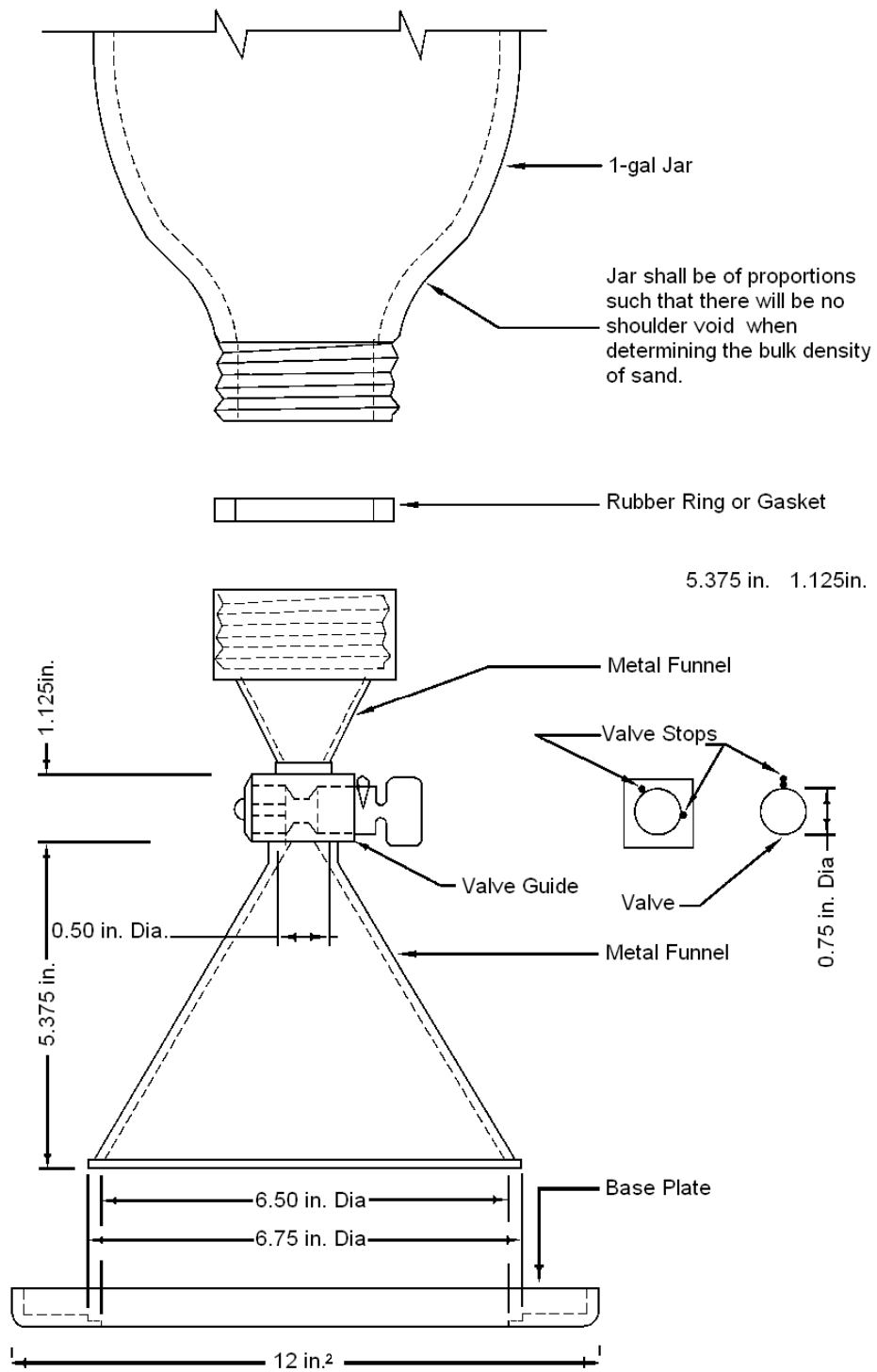

**FIGURE 1**

**CALIBRATION OF DENSITY SAND AND SAND CONE APPARATUS**  
**ARIZ 229**  
 (A Modification of AASHTO T191)

Date of Calibration: _____	Test Operator: _____
I. D. No. of Mold used in calibration: _____	
Volume of Mold used in calibration: _____	
Identification of Sand: _____	
Identification of Sand Cone Apparatus: _____	

Trial No.	Wt. of Baseplate and Mold Filled with Sand (grams)	Wt. of Baseplate and Empty Mold (grams)	Wt. of Sand to Fill Mold (grams)
1			
2			
3			

Average Weight of Sand to Fill Mold = \_\_\_\_\_ grams

$$\text{Density of Sand, } D_s = \frac{\text{Average Weight of Sand to Fill Mold}}{(453.6 \text{ grams / lb.}) \times (\text{Volume of Mold})}$$

$$D_s = \frac{\text{_____}}{(453.6) \times ( \quad )} = \text{_____ lb. /cu. ft.}$$

Trial No.	Initial Wt. of Apparatus (grams)	Final Wt. of Apparatus (grams)	Wt. of Sand to Fill Funnel and Baseplate (grams)
1			
2			
3			

Average Weight of Sand to Fill Funnel and Baseplate = \_\_\_\_\_ grams

$$\text{Volume of Funnel and Baseplate, } V_{fb} = \frac{\text{Average Weight of Sand to Fill Funnel and Baseplate}}{(453.6 \text{ grams / lb.}) \times (\text{Density of Sand})}$$

$$V_{fb} = \frac{\text{_____}}{(453.6) \times ( \quad )} = \text{_____ cu. ft.}$$

Remarks: _____
Supervisor and Date: _____
Calibration Expiration Date: _____

**FIGURE 2**

**CALIBRATION OF DENSITY SAND AND SAND CONE APPARATUS**  
**ARIZ 229**  
**(A Modification of AASHTO T191)**

Date of Calibration: _____	Test Operator: _____
I. D. No. of Mold used in calibration: <b>26</b>	
Volume of Mold used in calibration: <b>0.0751</b>	
Identification of Sand: _____	
Identification of Sand Cone Apparatus: _____	

Trial No.	Wt. of Baseplate and Mold Filled with Sand (grams)	Wt. of Baseplate and Empty Mold (grams)	Wt. of Sand to Fill Mold (grams)
1	9436	6649	2787
2	9430	6649	2781
3	9429	6649	2780

Average Weight of Sand to Fill Mold = 2783 grams

$$\text{Density of Sand, } D_s = \frac{\text{Average Weight of Sand to Fill Mold}}{(453.6 \text{ grams / lb.}) \times (\text{Volume of Mold})}$$

$$D_s = \frac{2783}{(453.6) \times (0.0751)} = 81.7 \text{ lb. /cu. ft.}$$

Trial No.	Initial Wt. of Apparatus (grams)	Final Wt. of Apparatus (grams)	Wt. of Sand to Fill Funnel and Baseplate (grams)
1	6348	4870	1478
2	6347	4871	1476
3	6345	4874	1471

Average Weight of Sand to Fill Funnel and Baseplate = 1475 grams

$$\text{Volume of Funnel and Baseplate, } V_m = \frac{\text{Average Weight of Sand to Fill Funnel and Baseplate}}{(453.6 \text{ grams / lb.}) \times (\text{Density of Sand})}$$

$$V_m = \frac{1475}{(453.6) \times (81.7)} = 0.0398 \text{ cu. ft.}$$

Remarks: _____
Supervisor and Date: _____
Calibration Expiration Date: _____

**FIGURE 3**