

Note to Designer: The information presented in this Standard Drawing has been prepared in accordance with recognized engineering principles and is for general use. It should not be used for specific application without competent professional examination and verification of its suitability and applicability by a licensed professional engineer. Contents within the inner border line shall not be altered.

PRIOR DISTRIBUTION DATE 11/04

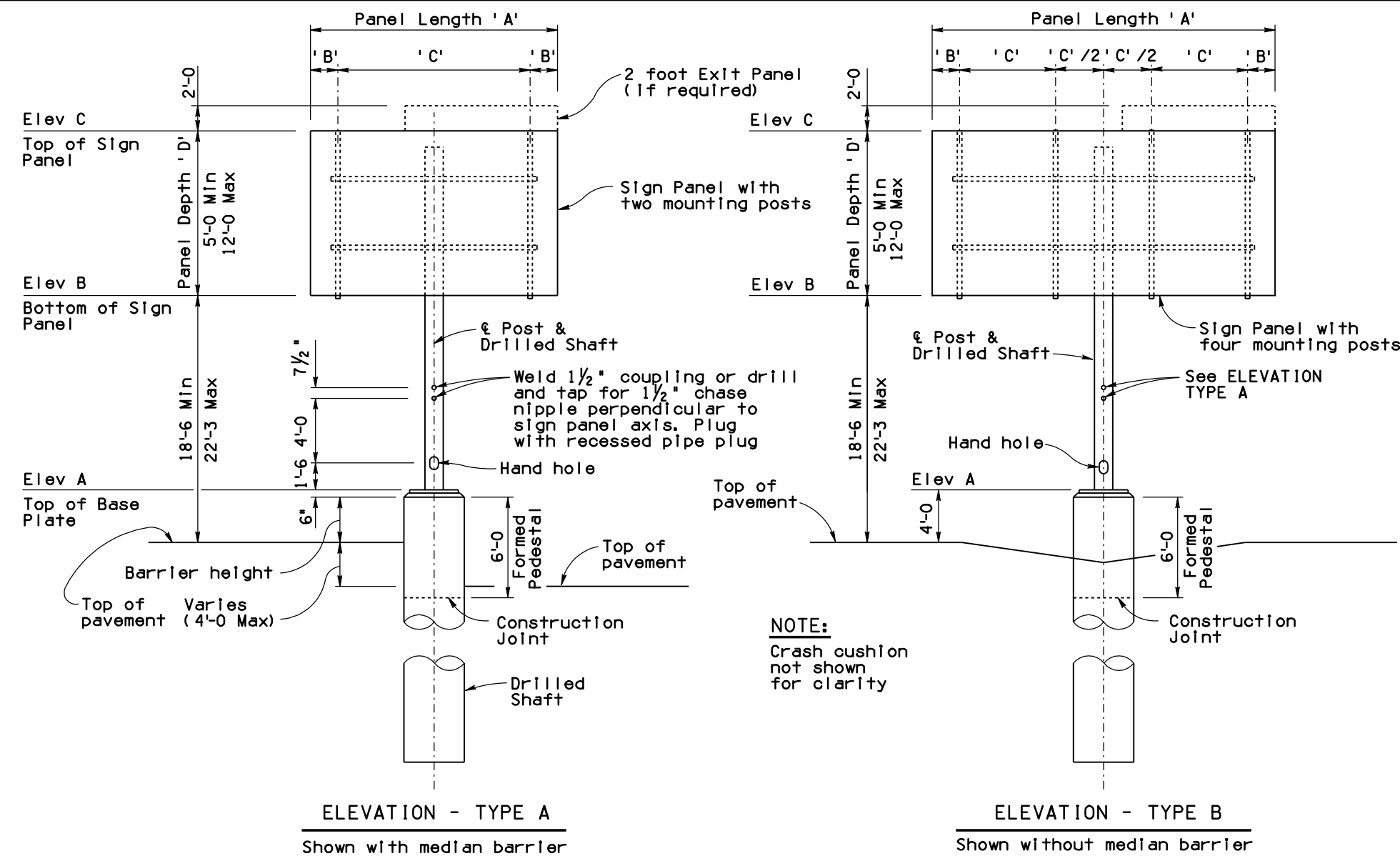

**ELEVATION - TYPE A**  
Shown with median barrier

**ELEVATION - TYPE B**  
Shown without median barrier

**NOTE:**  
Crash cushion not shown for clarity

**PAY ITEM NOTES:**

Pay Item for sign structure foundation includes the drilled shaft and the formed pedestal on drilled shaft and the anchor bolt assembly.

Item No. 6060163 SIGN STRUCTURE (MEDIAN) (TWO SIDED)  
Measure: Each

Item No. 6060239 FOUNDATION FOR SIGN STRUCTURE (MEDIAN)  
Measure: Each

Drilled shaft locations and top of drilled shaft elevations shall be field verified by the Contractor prior to fabrication of posts

	Dimensions	Nominal Pipe Dia Inches	Pipe Wall thickness Inches		
				'A'	'B'
Type A 2 Mounting Posts	8'-0"	1'-6"	5'-0"	14	0.938
	9'-0"	1'-9"	5'-6"	14	0.938
	10'-0"	2'-0"	6'-0"	14	0.938
	11'-0"	2'-0"	7'-0"	14	0.938
	12'-0"	2'-3"	7'-6"	14	0.938
Type B 4 Mounting Posts	13'-0"	2'-6"	8'-0"	14	0.938
	14'-0"	1'-0"	4'-0"	16	1.031
	15'-0"	1'-0"	4'-4"	16	1.031
	16'-0"	1'-0"	4'-8"	16	1.031
	17'-0"	1'-0"	5'-0"	16	1.031
	18'-0"	1'-0"	5'-4"	16	1.031
	19'-0"	1'-0"	5'-8"	16	1.031
	20'-0"	1'-6"	5'-8"	16	1.031
	21'-0"	1'-6"	6'-0"	20	0.750
	22'-0"	1'-6"	6'-4"	20	0.750
23'-0"	1'-6"	6'-8"	20	0.750	
24'-0"	1'-6"	7'-0"	20	0.750	
25'-0"	2'-0"	7'-0"	20	0.750	

**GENERAL NOTES:**

Construction Specification - Arizona Department of Transportation Standard Specifications for Road and Bridge Construction, latest Edition.

Design Specifications - AASHTO Standard Specification for Structural Supports for Highway Signs, Luminaires, and Traffic Signals, 6th Edition (2013) with 2015 Interim Revisions

All tubular structural cantilever pipe shall be welded or seamless steel pipe and shall conform to ASTM Specification (Fy = 35,000 psi):  
 A-53 Grade B, Type E or S  
 A252 Grade 2, Type E or S  
 A106 Grade B, Type S only  
 API 5L Grade B, Type E or S  
 API 5LX Grade X42, Type E or S

All other Structural Steel shall conform to ASTM Specification A36 unless noted otherwise.

All bolts shall conform to ASTM Specification F3125 GR A325.

All bolts, nuts and washers shall be galvanized in accordance with the requirements of ASTM A153. All other steel shall be galvanized after fabrication in accordance with ASTM A123.

Welding of structural tubing shall conform to the requirements of the American Welding Society, Structural Welding Code, D1.1, latest Edition.

All welding shall be continuous unless noted otherwise. All butt welds shall be full penetration using prequalified welding procedures and shall be tested by ultrasonic testing. All butt welds shall be ground flush, full width.

Grinding striations shall be parallel to the length of member.

The Column to base plate weld (WELD DETAIL A) shall be tested by ultrasonic testing. Any detected shallow toe cracks shall be repaired in the shop.

All Concrete shall be Class "S" (f'c = 3500 psi).

Reinforcing steel shall conform to ASTM Specification A615. All reinforcing shall be furnished as Grade 60.

All bends and hooks shall meet the requirements of AASHTO LRFD Article 5.10. All bend dimensions for reinforcing steel shall be out-to-out of bars. All placement dimensions for reinforcing steel shall be to center of bars unless noted otherwise.

Project Plans shall provide an elevation view of each sign structure with location (station and offset), Elev A, Elev B, Elev C, and Sign panel dimensions ('A', and 'D').

See Project Plans for length and location of exit panels, if required.

Dimensions shall not be scaled from drawings.

STANDARDS ENGINEER <b>A. ALZUBI</b> RECOMMENDED FOR APPROVAL GROUP MANAGER APPROVED <b>D. EBERHART</b> STANDARDS COMMITTEE APPROVED FOR DISTRIBUTION	ARIZONA DEPARTMENT OF TRANSPORTATION INFRASTRUCTURE DELIVERY AND OPERATIONS DIVISION BRIDGE GROUP STANDARD DRAWING	DRAWING NO. <b>SD 9.01</b> (1 of 5)
DATE 04/19	<b>MEDIAN SIGN STRUCTURE (TWO SIDED)          ELEVATION AND NOTES</b>	

Note to Designer: This Standard Drawing has been prepared in accordance with recognized engineering principles and is for general use. It should not be used for specific application without competent professional examination and verification of its suitability and applicability by a licensed professional engineer. Contents within the inner border line shall not be altered.

PRIOR DISTRIBUTION DATE 04/19

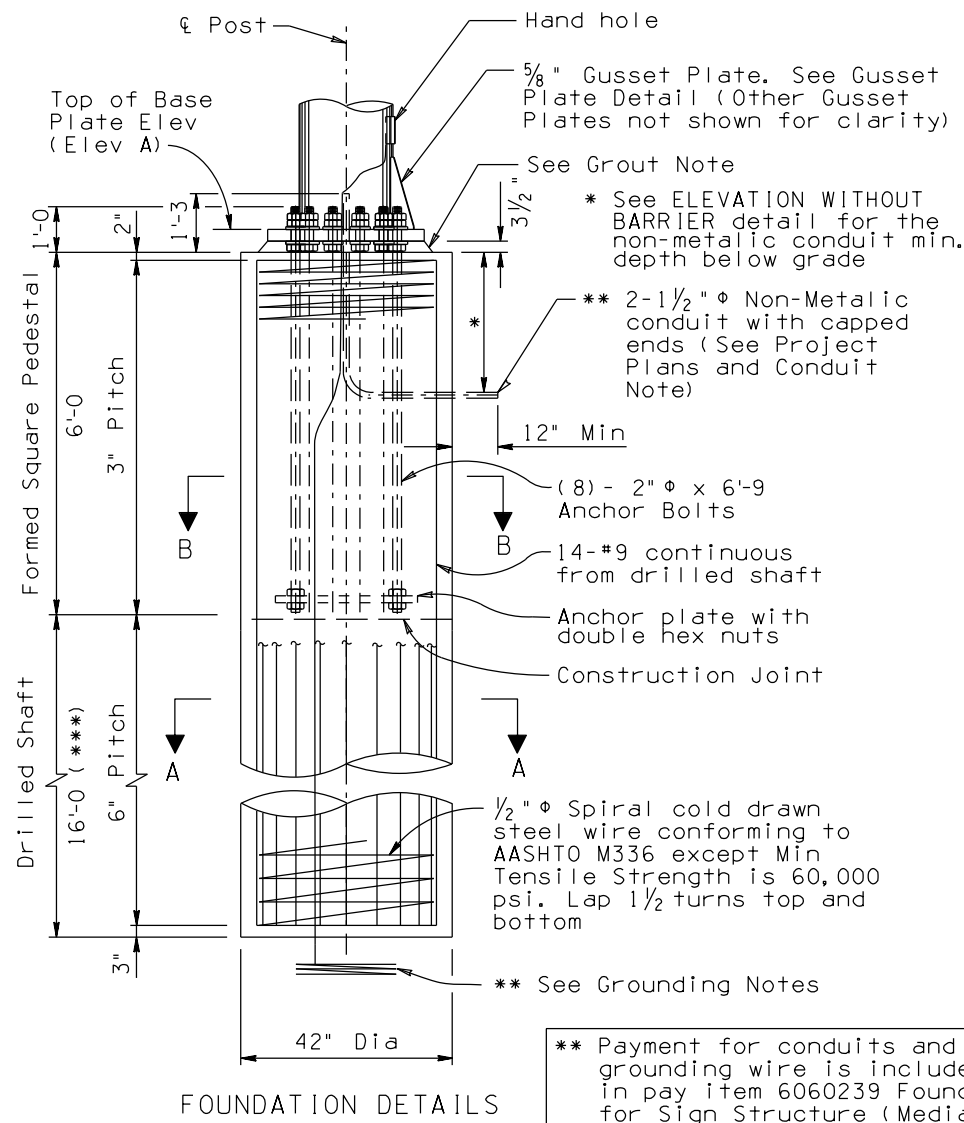

(\*\*\*) Drilled shaft depth is based on uniform soils condition with unit weight = 110 pcf, friction angle phi = 29 degrees, modulus of subgrade reaction K=50 psf/ft. Depth or design of the drilled shaft shall be revised by the Engineer of Record for weaker soils or rock embedment, and all revision shall be shown on the project plans.

**GUSSET PLATE NOTE:**

Gusset plates shall be placed perpendicular to base plate and post face, and centered between anchor bolt holes.

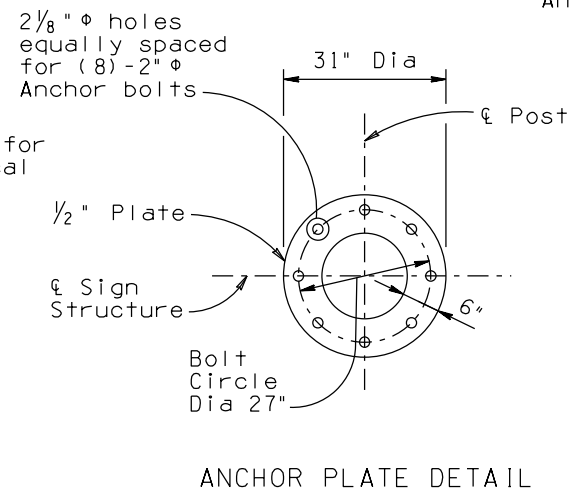
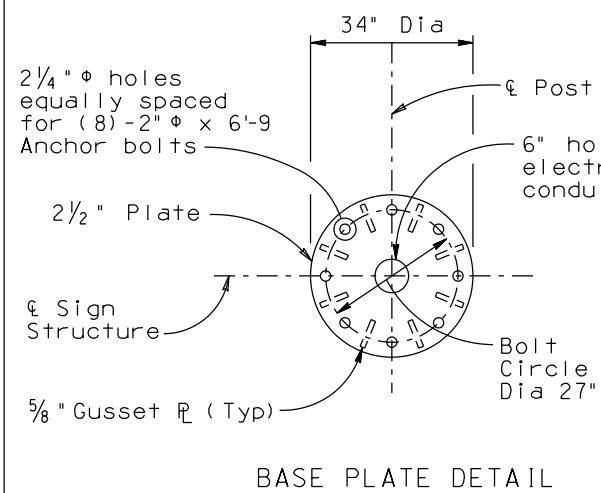

**NOTES:**

All anchor bolts shall conform to ASTM F1554 Grade 55 Specifications. The upper 1'-2 and lower 6" shall be threaded. The upper 1'-8 shall be galvanized in accordance with the requirements of ASTM A153.

Provide 2 Hardened Steel washers, 2 Hex nuts and one leveling nut for each bolt. At final position of post, all top and bottom anchor bolt nuts shall be wrench tightened against base plate.

Drilled shaft concrete shall be class 'S' concrete and placed against undisturbed material or compacted embankment.

Provide bolt template during installation of anchor bolts. The bolt template shall be fabricated of 1/4" thick (Min) steel plate, similar to anchor plate details, and both the bolt template and the anchor plate shall be drilled to match the base plate.

**GROUNDING NOTES:**

A 25 feet long coil of No. 4 AWG bare copper grounding wire shall be installed before concrete is poured and shall be connected to the post grounding screw in the hand hole.

The grounding wire shall be installed on the outside of the conduit.

**CONDUIT NOTE:**

If the project plans do not call out for the installation of a conduit, 2-1/2" diameter non-metallic conduits shall be stubbed out 30" below grade. The stubbed conduit shall be perpendicular to traffic direction, be a minimum of 12" from edge of foundation cap, and the conduit ends shall be capped.

**GROUT NOTE:**

Space to be filled with non-shrink grout after tubular structure is permanently erected.

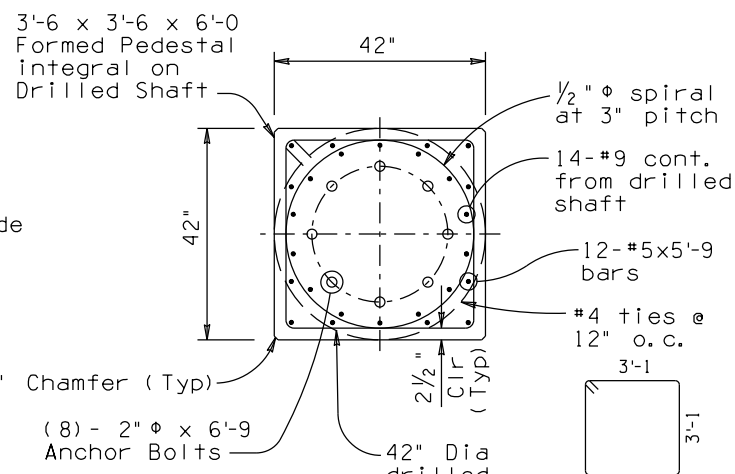

SECTION B-B

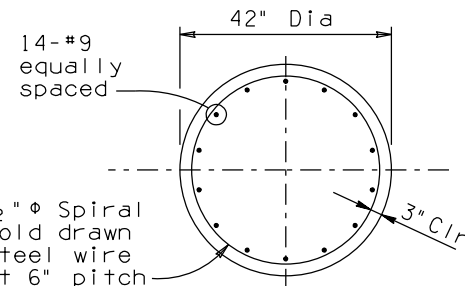

SECTION A-A

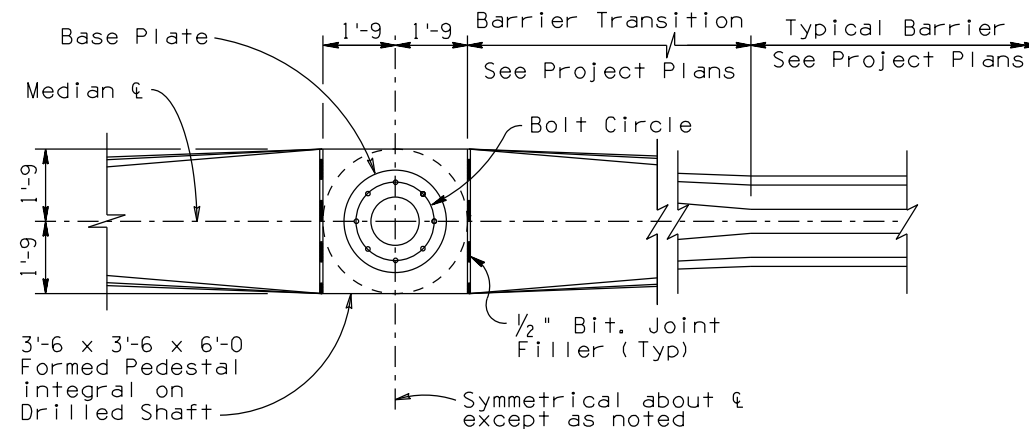

PLAN WITH BARRIER

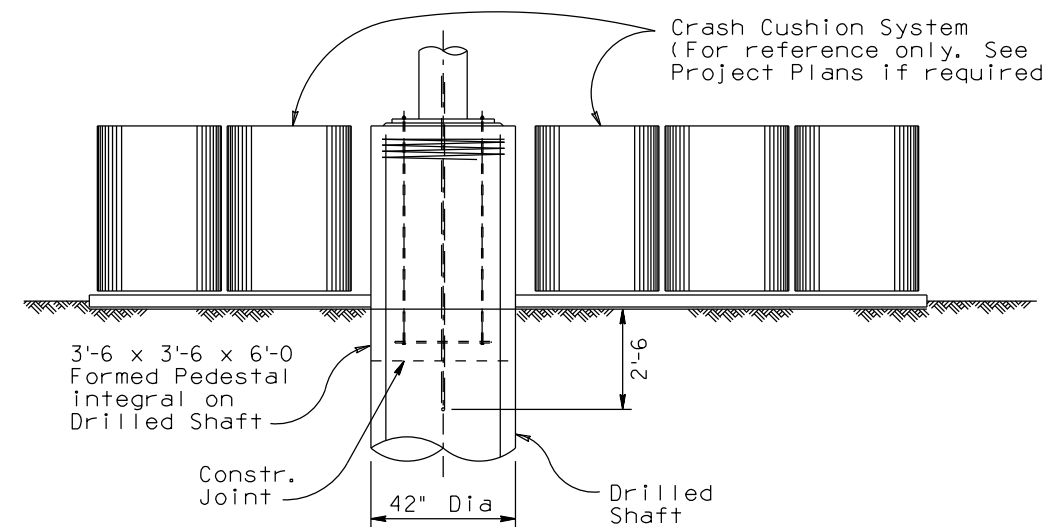

ELEVATION WITHOUT BARRIER

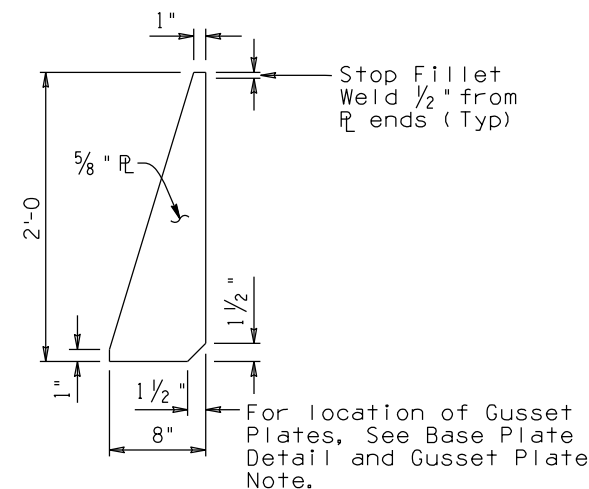

GUSSET PLATE DETAIL

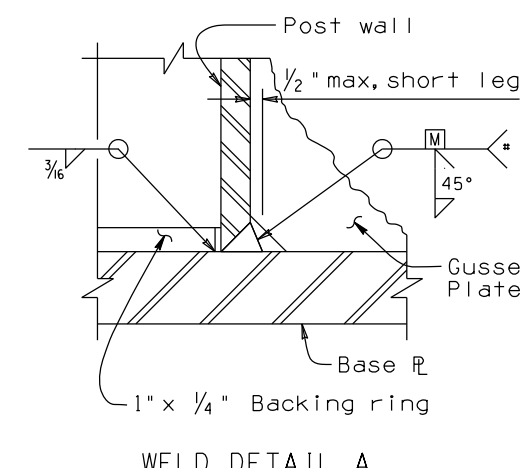

WELD DETAIL A

\* Preheat per AWS requirements

STANDARDS ENGINEER	A. ALZUBI
RECOMMENDED FOR APPROVAL	
GROUP MANAGER	D. EBERHART
APPROVED	
STANDARDS COMMITTEE APPROVED FOR DISTRIBUTION	03/22 DATE

ARIZONA DEPARTMENT OF TRANSPORTATION INFRASTRUCTURE DELIVERY AND OPERATIONS DIVISION <b>BRIDGE GROUP STANDARD DRAWING</b>	
MEDIAN SIGN STRUCTURE (TWO SIDED) FOUNDATION DETAILS	DRAWING NO. SD 9.01 (2 of 5)

Note to Designer: This Standard Drawing has been prepared in accordance with recognized engineering principles and is for general use. It should not be used for specific application without competent professional examination and verification of its suitability and applicability by a licensed professional engineer. Contents within the inner border line shall not be altered.

PRIOR DISTRIBUTION DATE 04/00

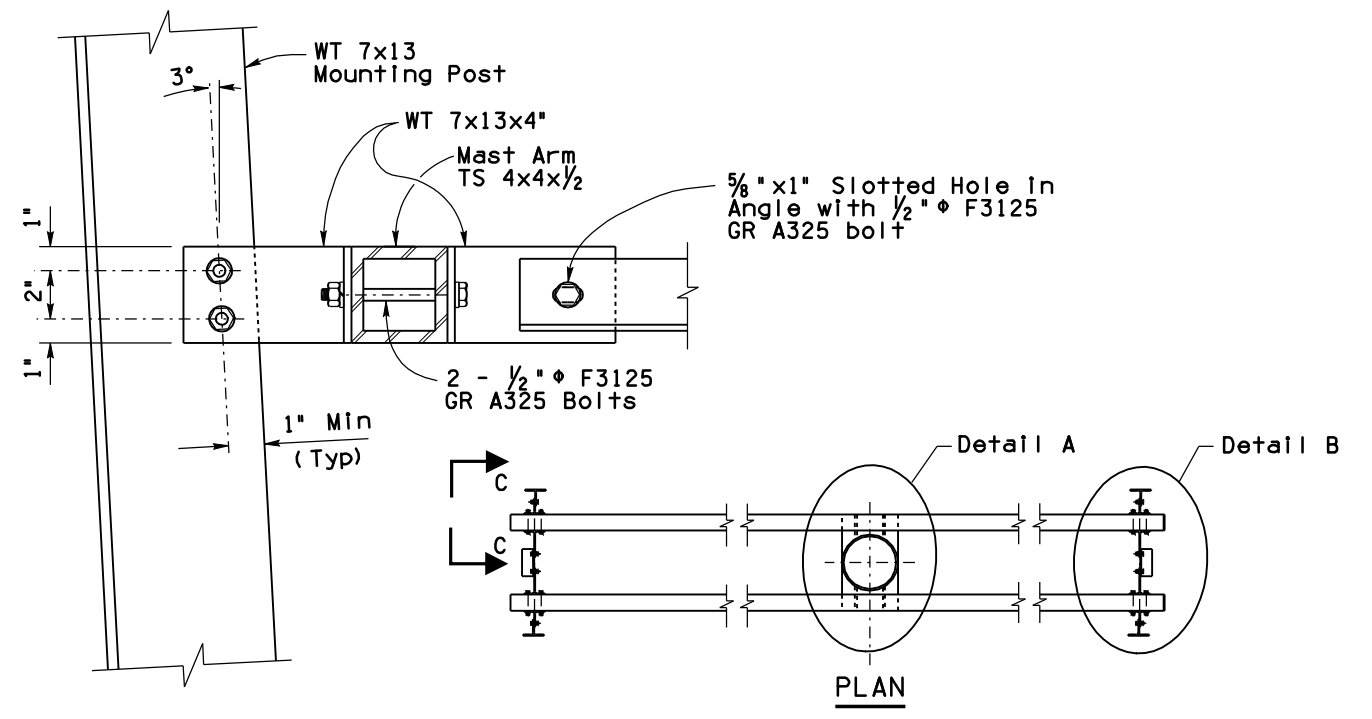
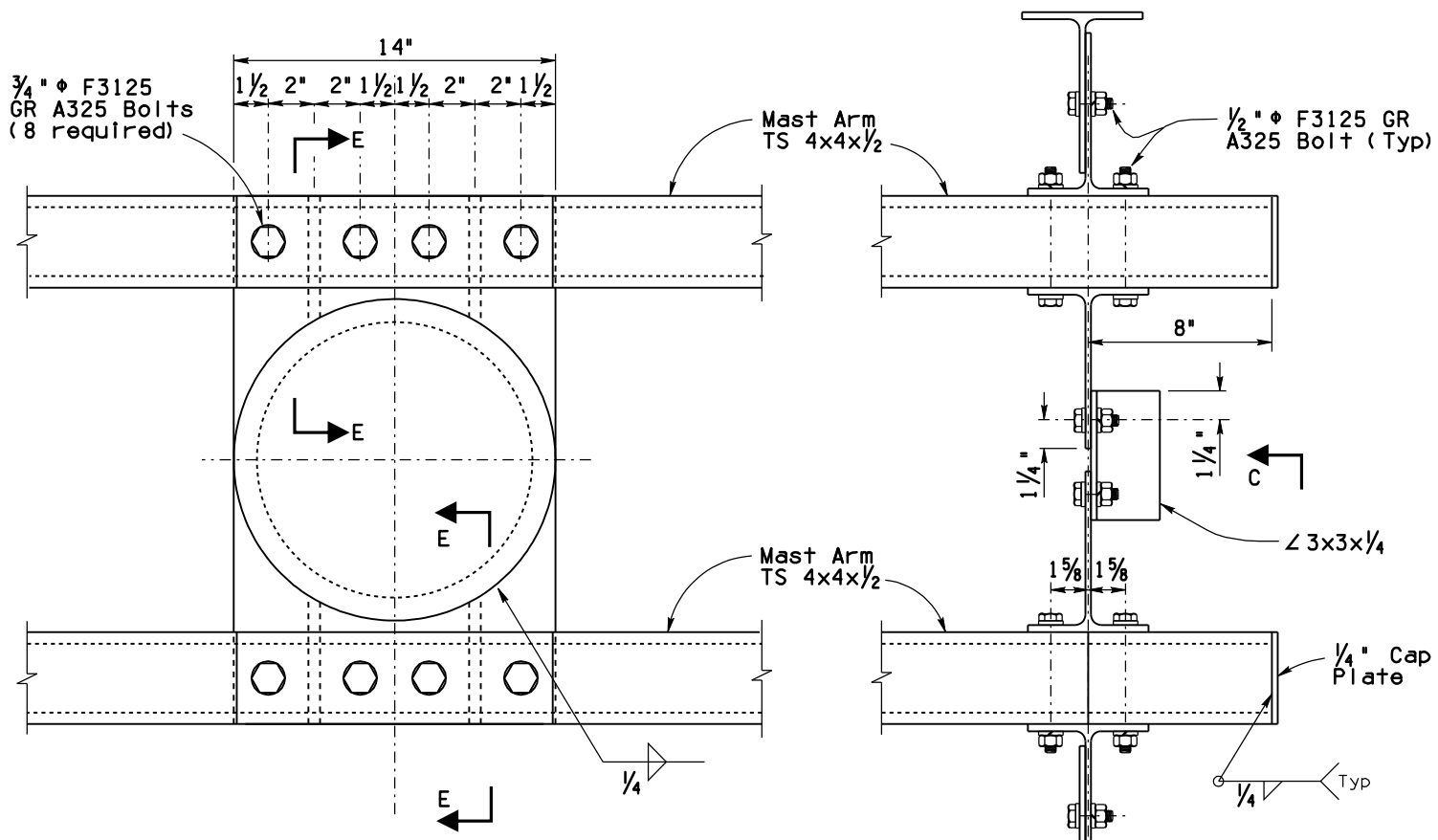

DETAIL A

DETAIL B

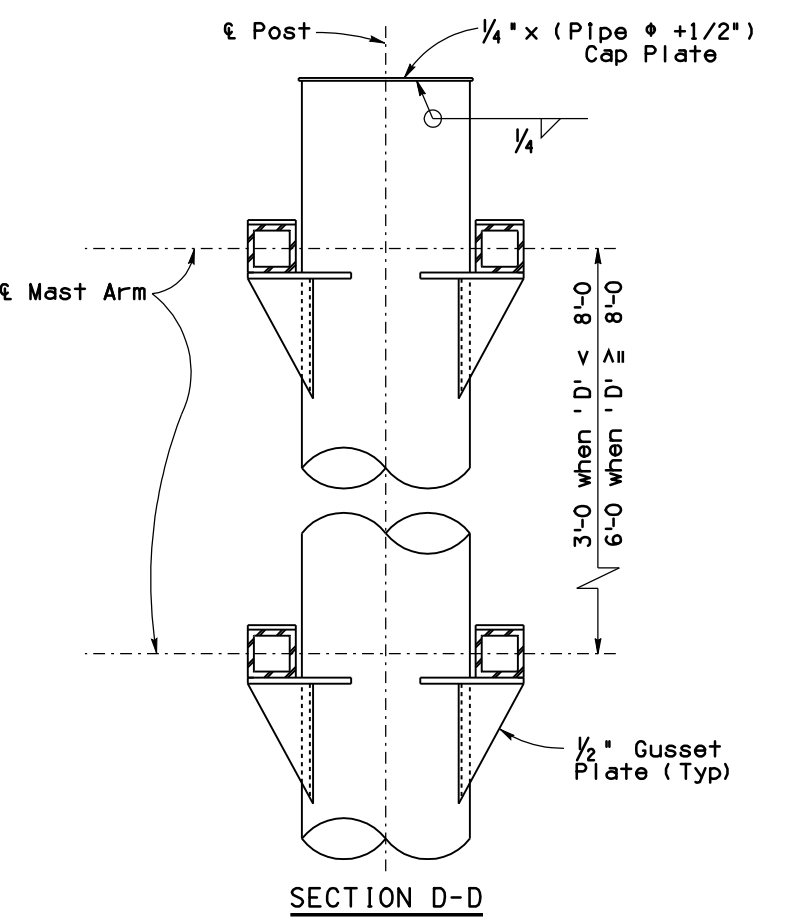

SECTION D-D

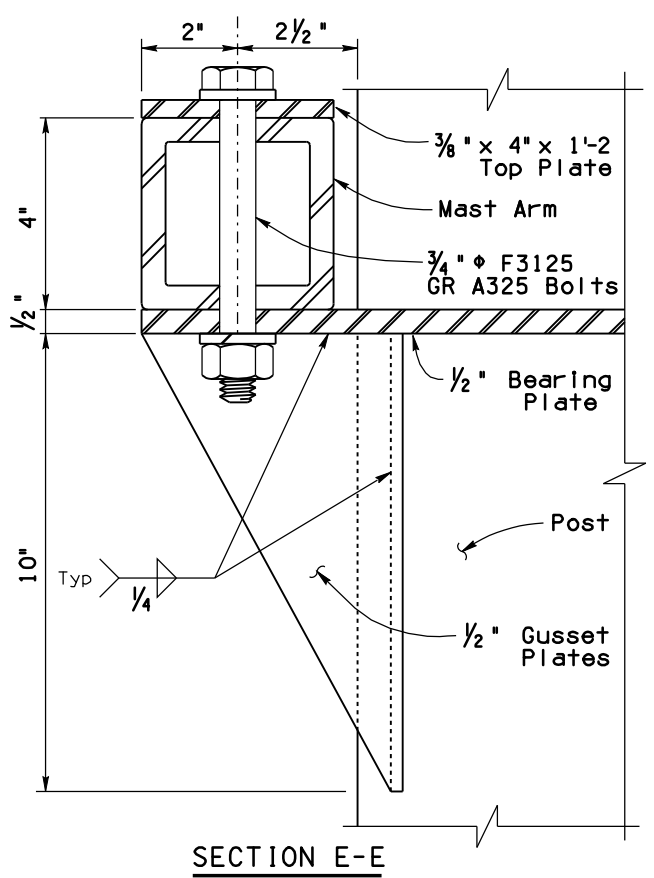

SECTION E-E

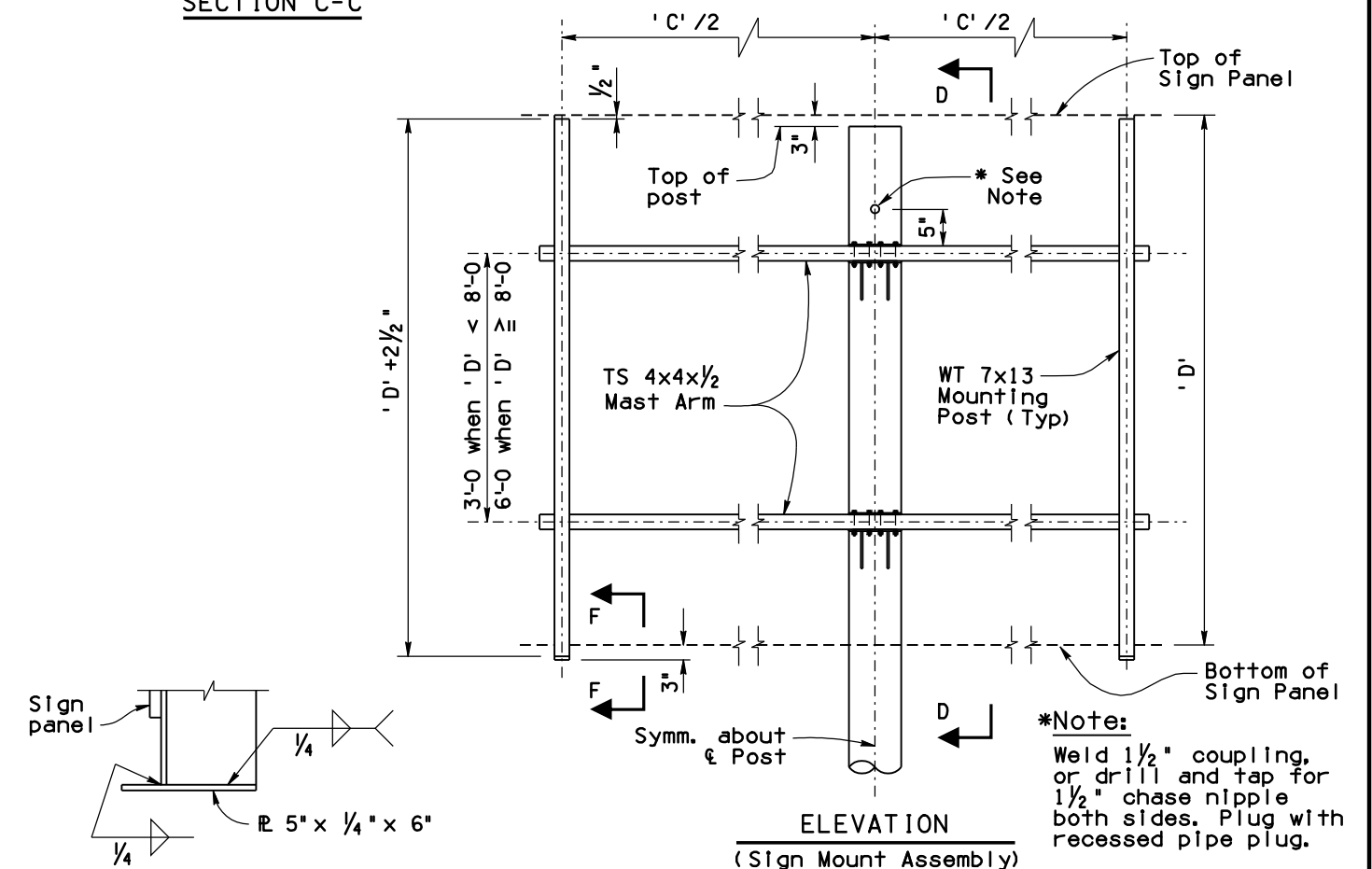

ELEVATION  
(Sign Mount Assembly)

VIEW F-F

TYPE A FRAME

STANDARDS ENGINEER  
**A. ALZUBI**  
 RECOMMENDED FOR APPROVAL  
 GROUP MANAGER  
**D. EBERHART**  
 APPROVED  
 STANDARDS COMMITTEE APPROVED FOR DISTRIBUTION 04/19 DATE

ARIZONA DEPARTMENT OF TRANSPORTATION  
 INFRASTRUCTURE DELIVERY AND OPERATIONS DIVISION  
 BRIDGE GROUP STANDARD DRAWING  
 MEDIAN SIGN STRUCTURE (TWO SIDED)  
 TYPE A SIGN MOUNT ASSEMBLY  
 DRAWING NO.  
 SD 9.01  
 (3 of 5)

Note to Designer: This Standard Drawing has been prepared in accordance with recognized engineering principles and is for general use. It should not be used for specific application without competent professional examination and verification of its suitability and applicability by a licensed professional engineer. Contents within the inner border line shall not be altered.

PRIOR DISTRIBUTION DATE 04/00

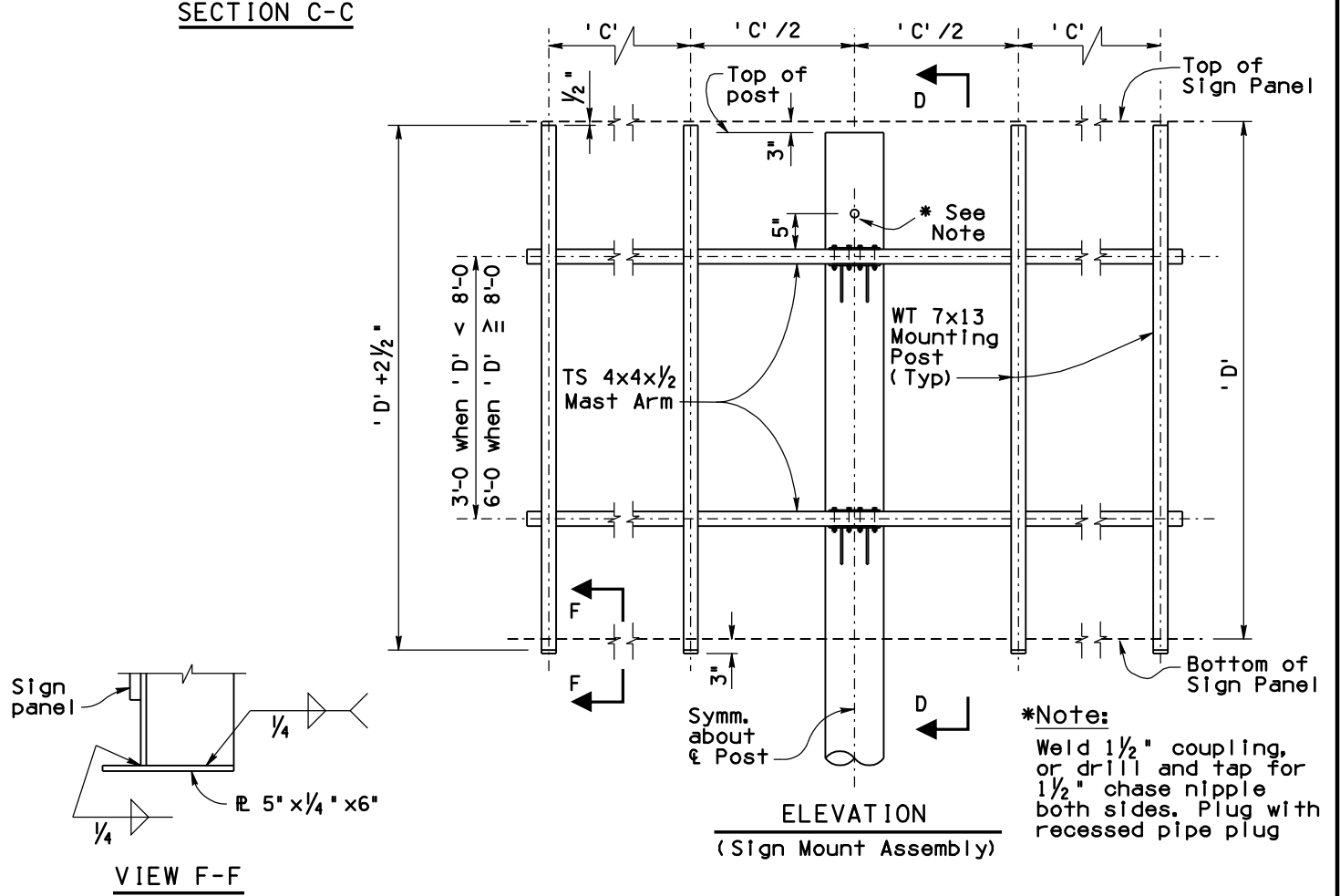
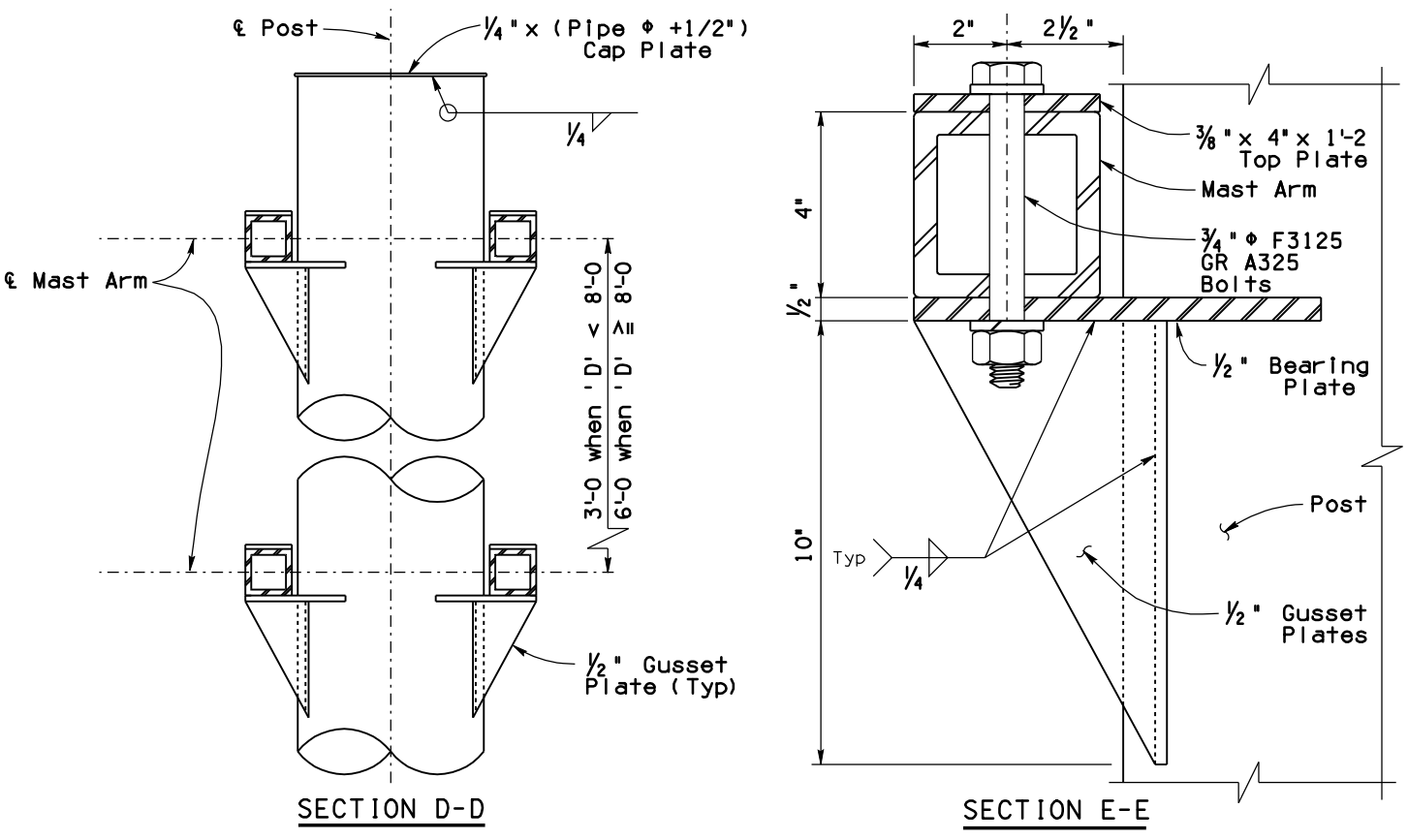
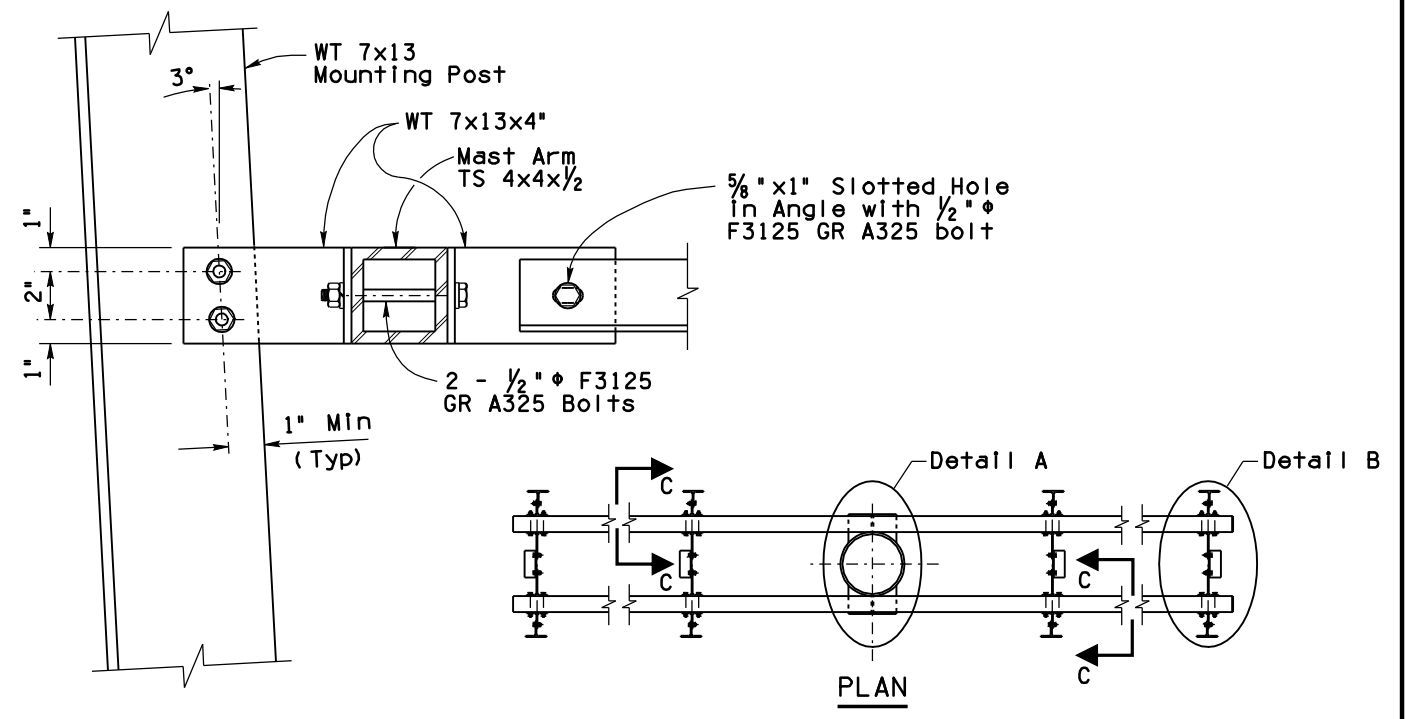
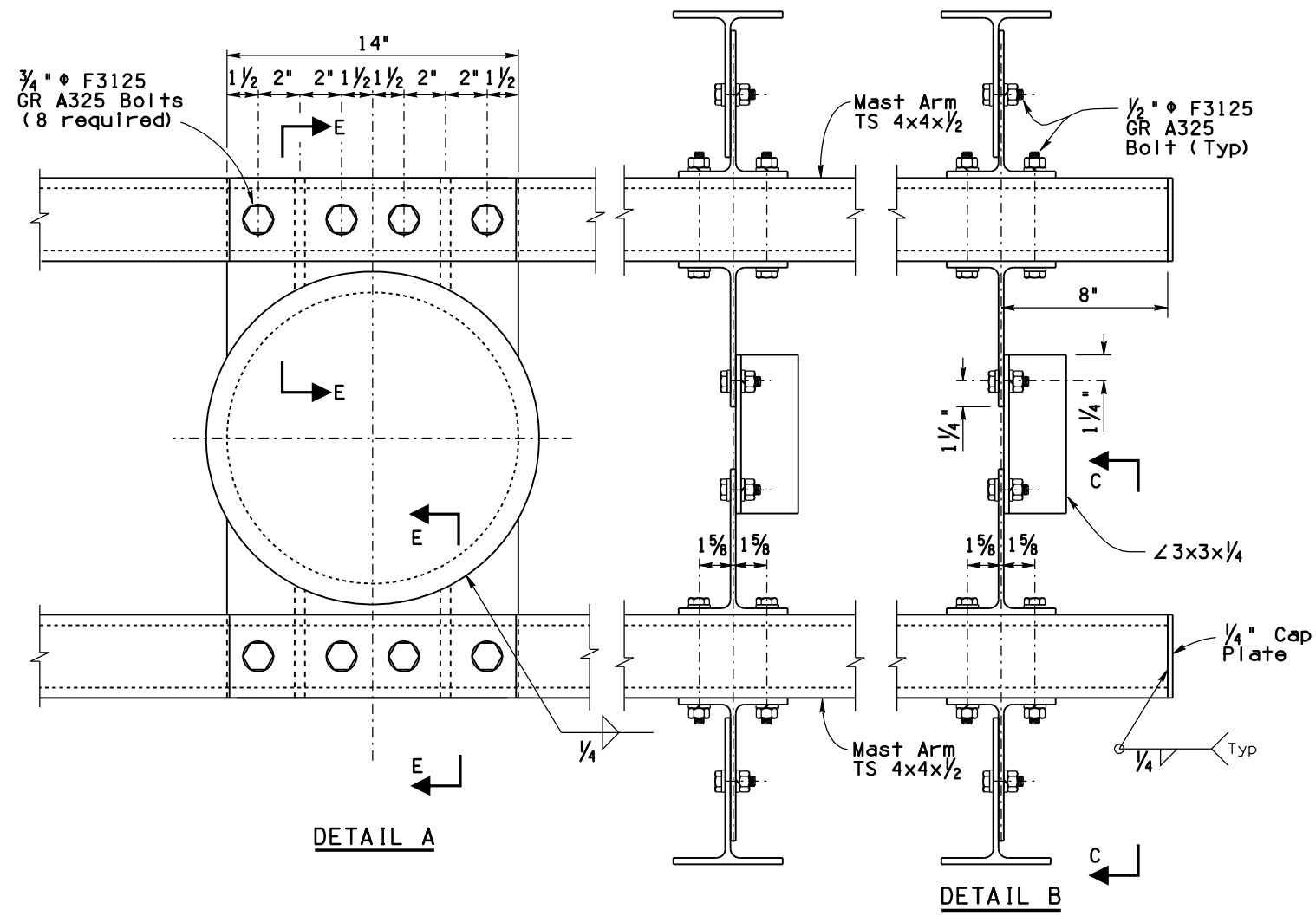

**TYPE B FRAME**

STANDARDS ENGINEER <b>A. ALZUBI</b>	ARIZONA DEPARTMENT OF TRANSPORTATION INFRASTRUCTURE DELIVERY AND OPERATIONS DIVISION BRIDGE GROUP STANDARD DRAWING
RECOMMENDED FOR APPROVAL GROUP MANAGER <b>D. EBERHART</b>	
APPROVED	
STANDARDS COMMITTEE APPROVED FOR DISTRIBUTION	
DATE 04/19	
MEDIAN SIGN STRUCTURE (TWO SIDED) TYPE B SIGN MOUNT ASSEMBLY	DRAWING NO. SD 9.01 (4 of 5)

Note to Designer: The information presented in this Standard Drawing has been prepared in accordance with recognized engineering principles and is for general use. It should not be used for specific application without competent professional examination and verification of its suitability and applicability by a licensed professional engineer. Contents within the inner border line shall not be altered.

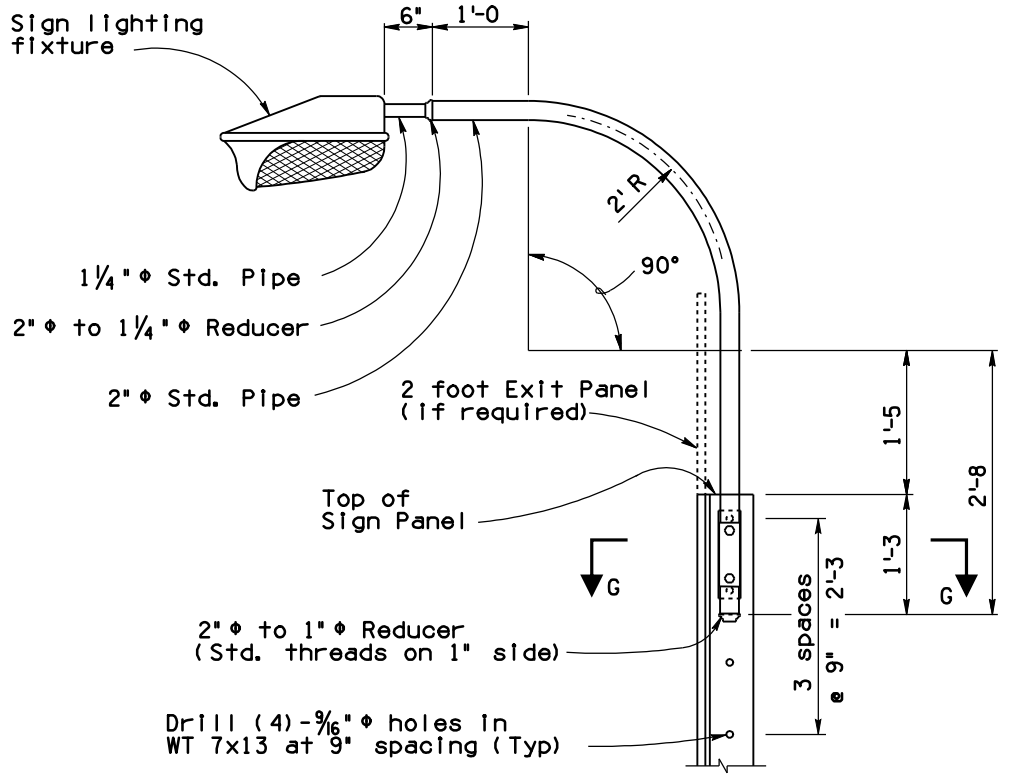

**OVERHEAD LIGHT SUPPORT DETAIL**

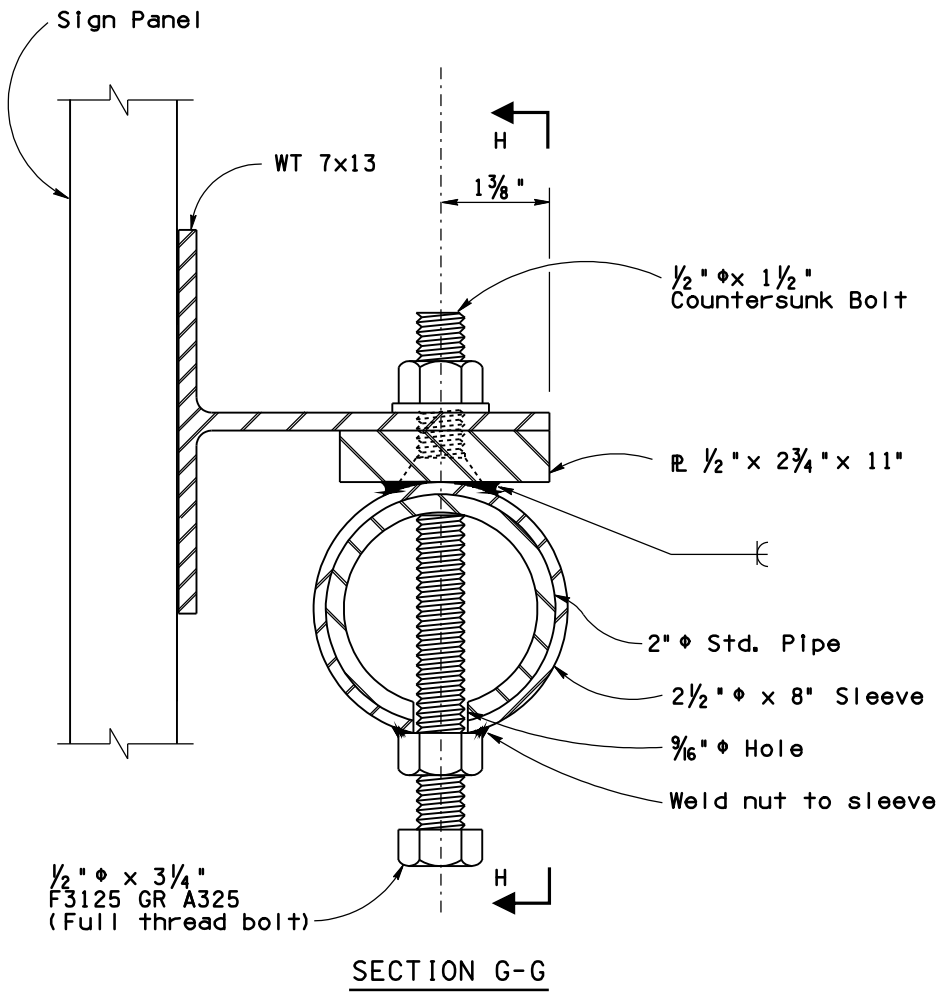

**SECTION G-G**

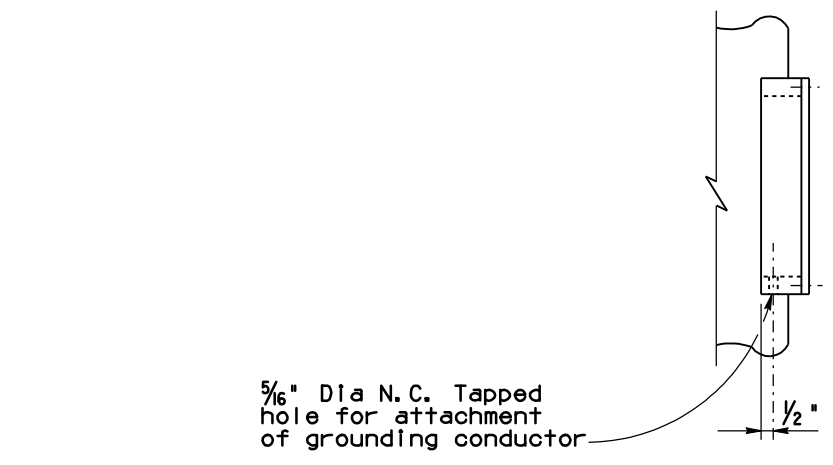

**ELEVATION H-H**

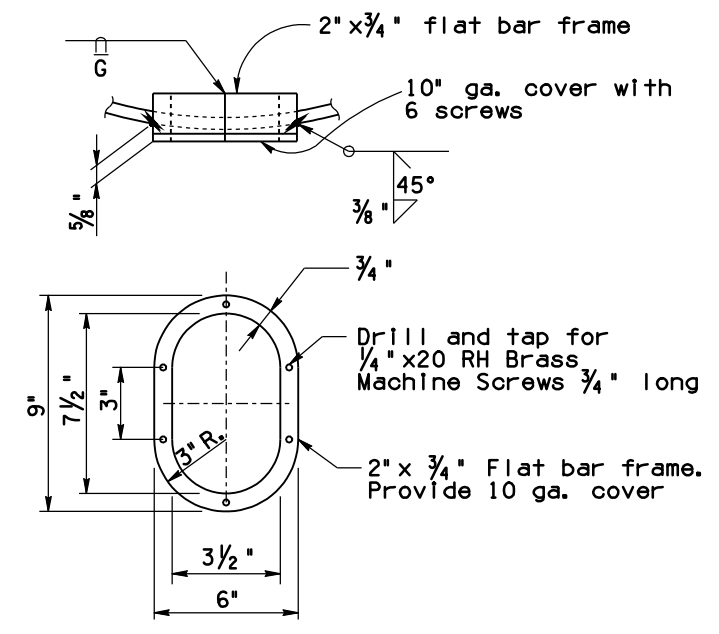

**HAND HOLE & COVER DETAILS**

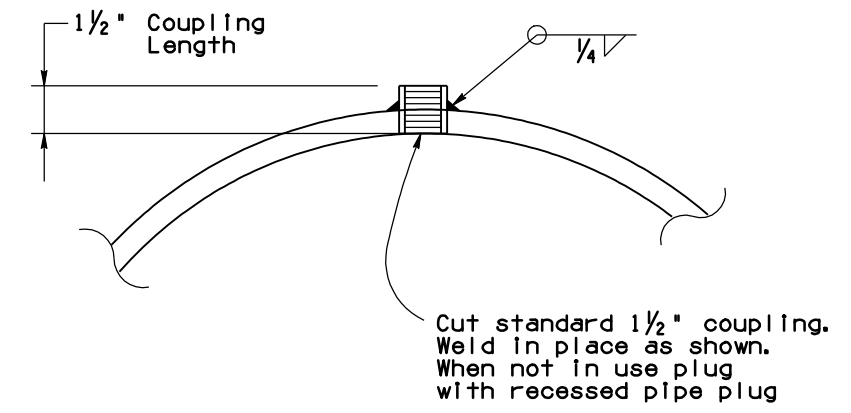

**COUPLING DETAIL**

5/16" hole in  
 2" Std. Pipe and  
 2 1/2" Std. Pipe  
 Sleeve for 1/2" F3125 GR A325 Bolt

5/16" Hole for 1/2" Countersunk Bolt, Cut Washer, and Hex Nut

PRIOR DISTRIBUTION DATE 04/00

STANDARDS ENGINEER <b>A. ALZUBI</b> RECOMMENDED FOR APPROVAL GROUP MANAGER <b>D. EBERHART</b> APPROVED STANDARDS COMMITTEE APPROVED FOR DISTRIBUTION	ARIZONA DEPARTMENT OF TRANSPORTATION INFRASTRUCTURE DELIVERY AND OPERATIONS DIVISION BRIDGE GROUP STANDARD DRAWING	DRAWING NO. <b>SD 9.01</b> (5 of 5)
MEDIAN SIGN STRUCTURE (TWO SIDED) LIGHT SUPPORT DETAILS		DATE 04/19